

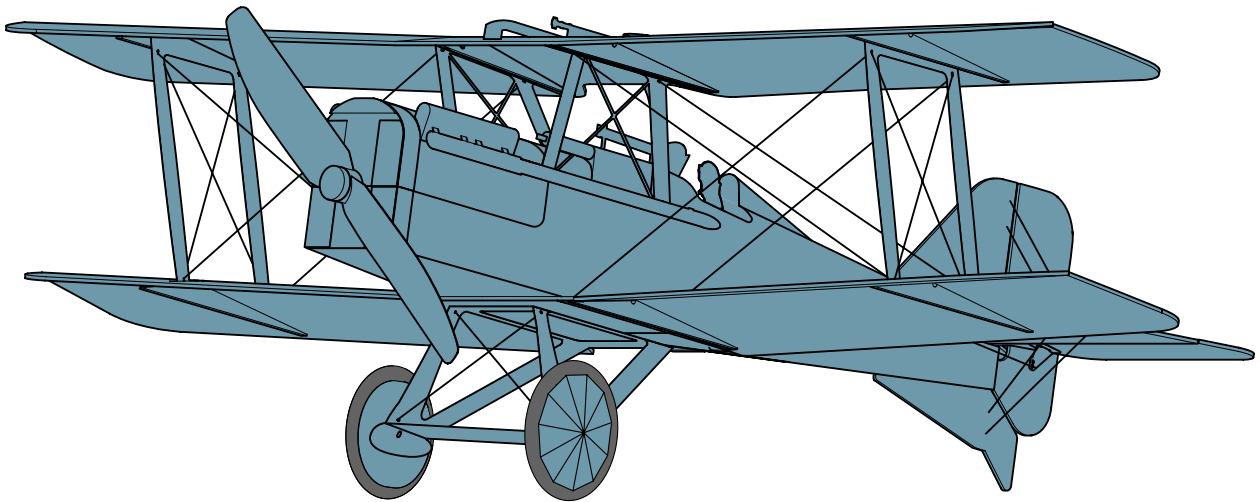

# ASSEMBLY GUIDE



Royal Aircraft Factory

# SE5a

Version 2



### Introduction

Thank you for purchasing this Microaces Aero Kit. Designed using innovative ideas, advanced materials and detailed aircraft illustrations, this 1/24th scale aircraft will bring you hours of building enjoyment and many more exciting flying hours too. Please take your time to familiarise yourself with these instructions as the aircraft assembles in a very unique way, following a sequence of steps that should be adhered too to ensure a satisfactory and flyable model.

### Safety

It is extremely important to us that you and those around you remain safe while building and flying Microaces kits. Please take note of the following notices of safety. Microaces Aero kits contain parts and packaging **unsuitable** for handling by small children. Please ensure that children under the age of 6 years are prevented from handling the component parts or packaging of this kit. Although the resulting model is lightweight, we **DON'T** recommend that you fly it near or over others where there is a danger of striking someone. We **DO** recommend that the maiden flight is performed over long grass in calm weather away from others.











### Assembly

Read all the instructions carefully before starting assembly.  
It is important to use the recommended glues or an equivalent with similar properties. Foam parts must be glued with a foam safe cement or permanent damage can result to components. Ensure your knife has a fresh or sharp blade installed to ensure a clean cut.

### Warranty

Microaces warrants this kit is supplied with all components present and that those components are free from cosmetic or structural damage to an extent that would impair the assembly of the kit, alter the aesthetics of the built model and/or the flight performance of the resulting model. If any parts are missing or damaged please contact us via email at: [support@microaces.com](mailto:support@microaces.com)

### Key

- |   |  |
|---|--|
|  Note (Information)                |  Attention             |
|  Part Number                       |  Do Not Glue           |
|  Contact Adhesive (Foam Safe)      |  Score before assembly |
|  Aliphatic Resin (or Foam Safe CA) |  Cut                   |
|  Paint                             |  Sanding Required      |
|  Area of adhesion for glue         |  |

## KIT PARTS

### Sheet Parts

1 x 2mm Laser cut foam airframe  
1 x 1mm printed & laser cut foam fuselage  
1 x 1mm printed & laser cut foam flight surfaces  
1 x laser cut polypropylene parts sheet  
1 x polyester sticker sheet  
1 x 0.8mm laser cut plywood motor mount

### Loose Parts

2 x rubber tyres  
1 x 4mm Ø plastic tube  
6 x 3mm Ø x 1mm neodymium magnets  
1 x 140mm x 0.4mm x 1mm carbon fibre strip  
2 x 500mm x 0.4mm x 1mm carbon fibre strip  
1 x 80mm x 1mm Ø carbon fibre rod  
1 x piano wire elevator control rod  
1 x piano wire rudder control rod  
1 x profile pilot figure  
1 x Spectra rigging wire

## RECOMMENDED TOOLS/GLUES

Knife or Scalpel with fresh blade

Steel Rule or straight edge

Sanding Stick or sand paper (180 grit recommended)

Tweezers

Needle nose pliers

UHU por foam safe adhesive (For foam & plastic)

Aliphatic Resin or Foam safe cyano glue (for rigging & re-inforcement)

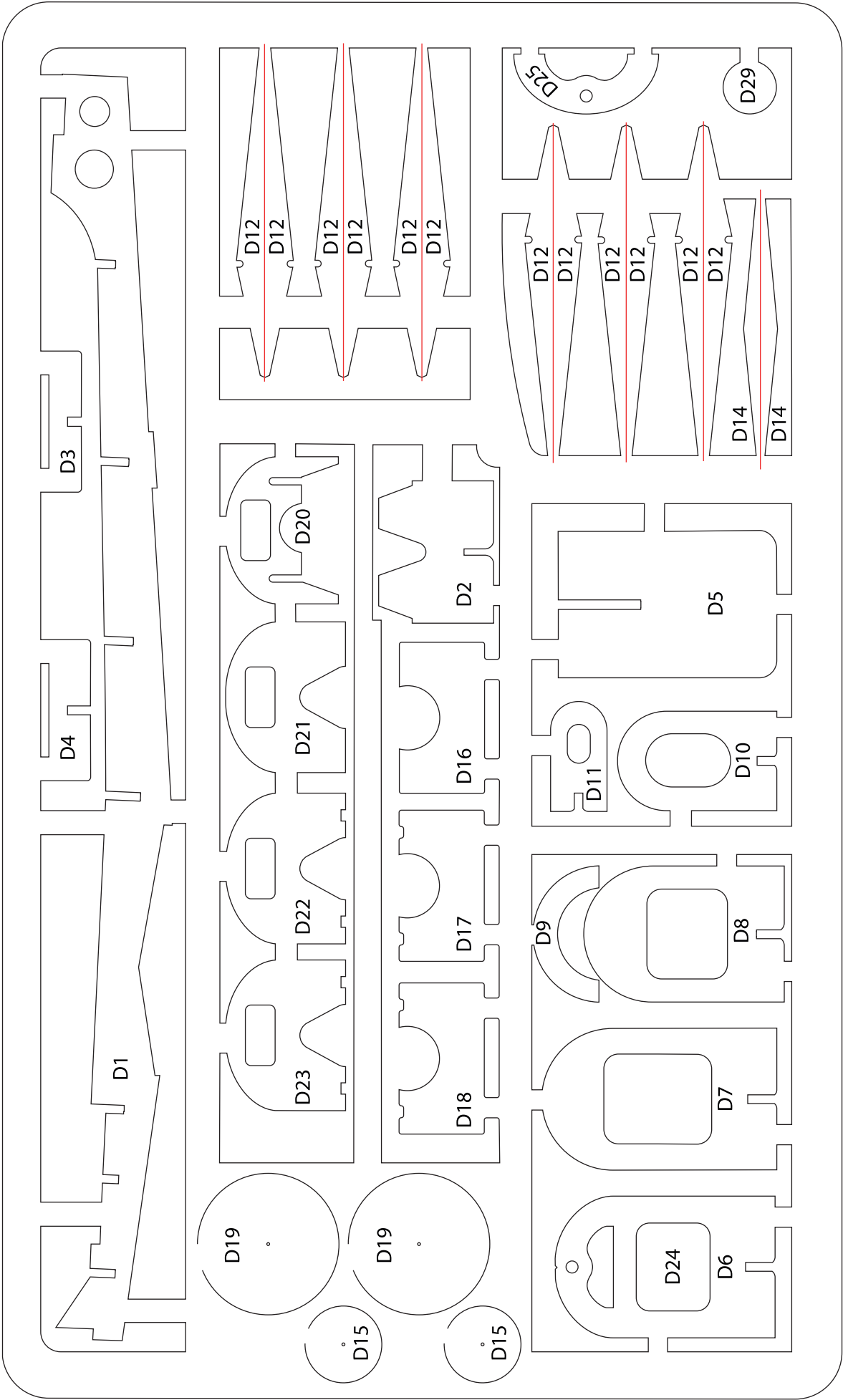

**1mm FOAM**

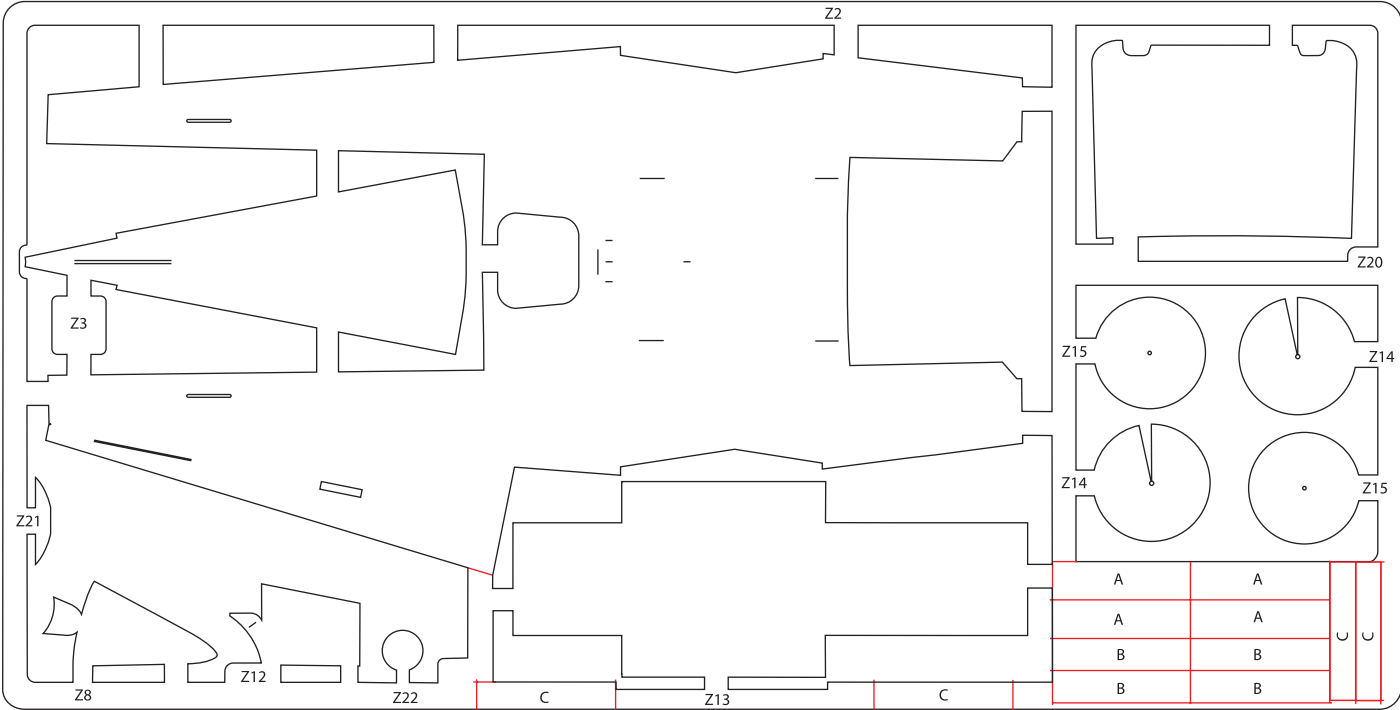

**1mm FOAM**

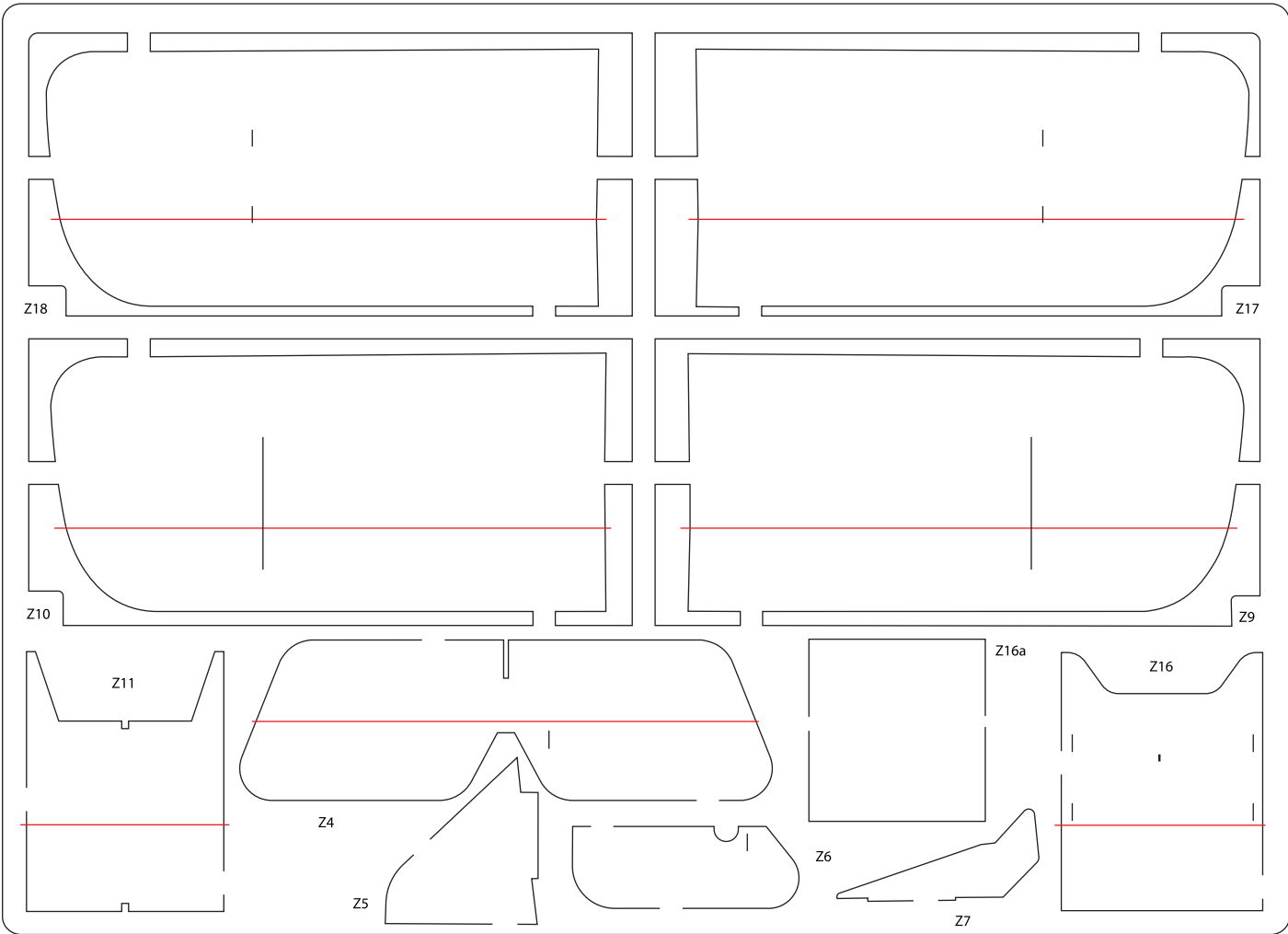

**PLASTIC PARTS**

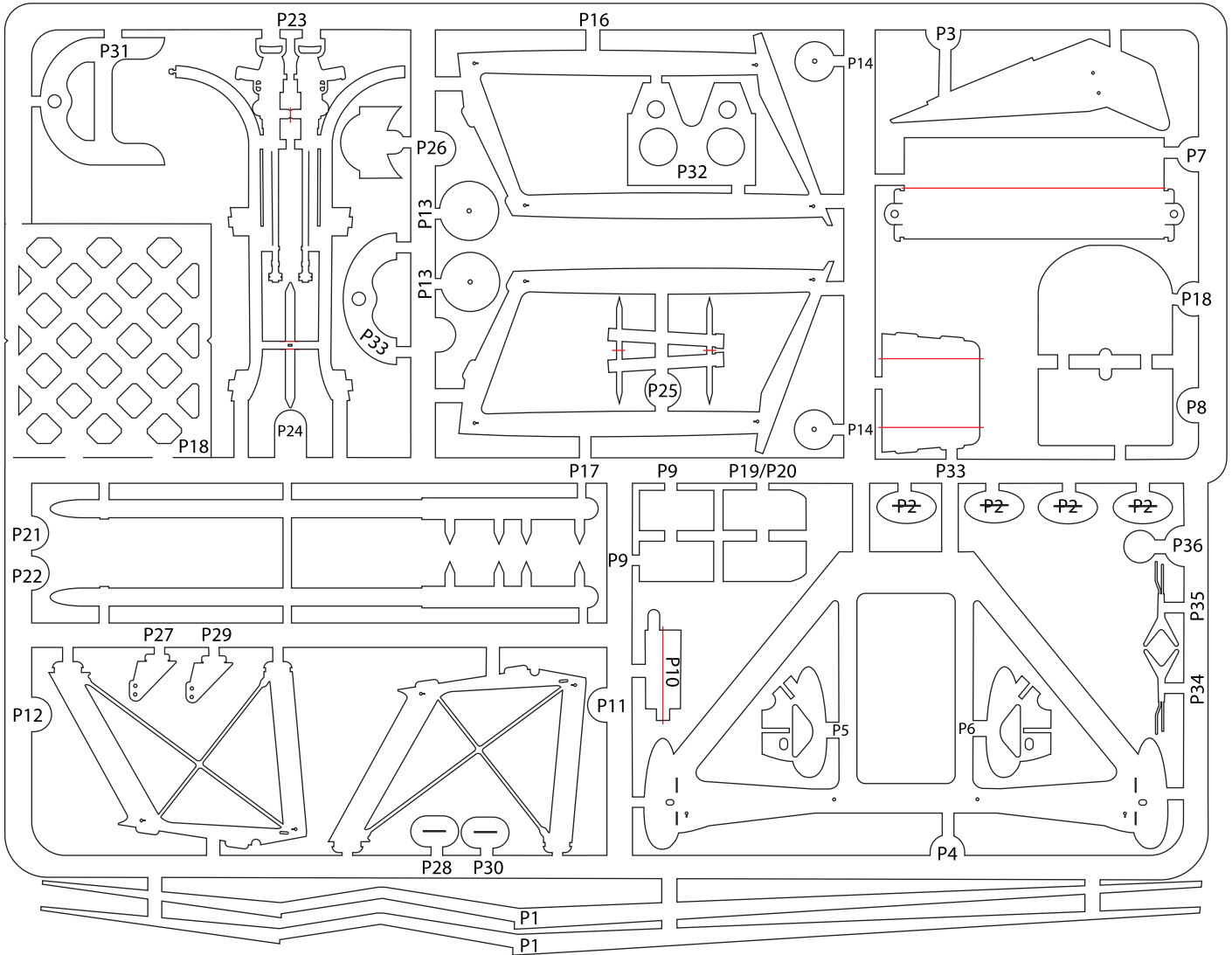

**0.8mm PLYWOOD**

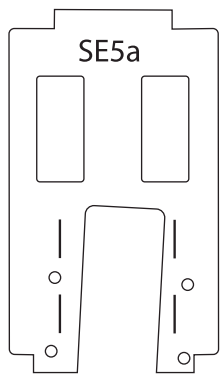

**PILOT**

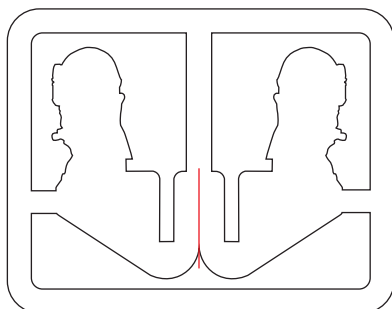

**STICKERS**

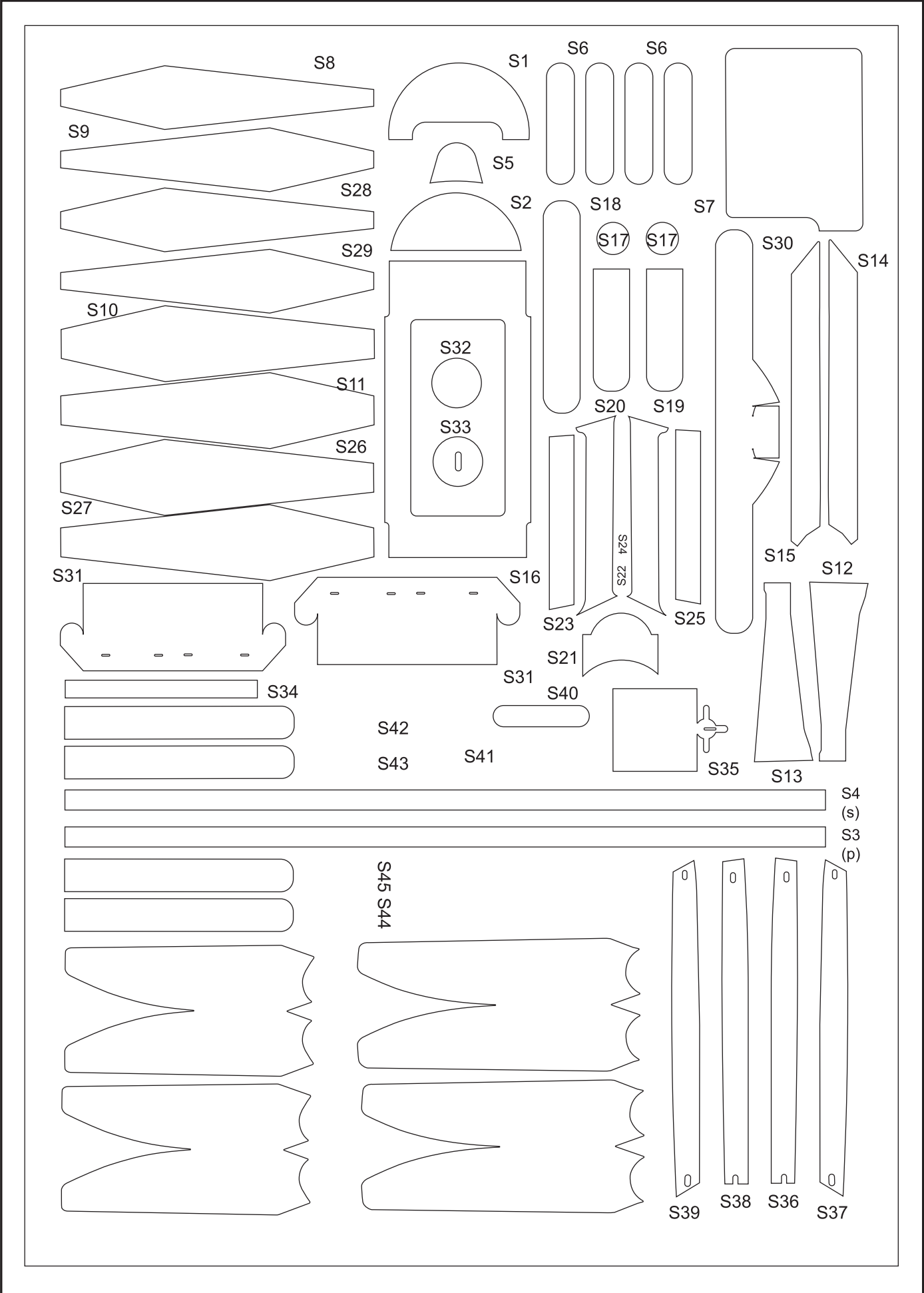

# SCORING & BEVELING GUIDE #1

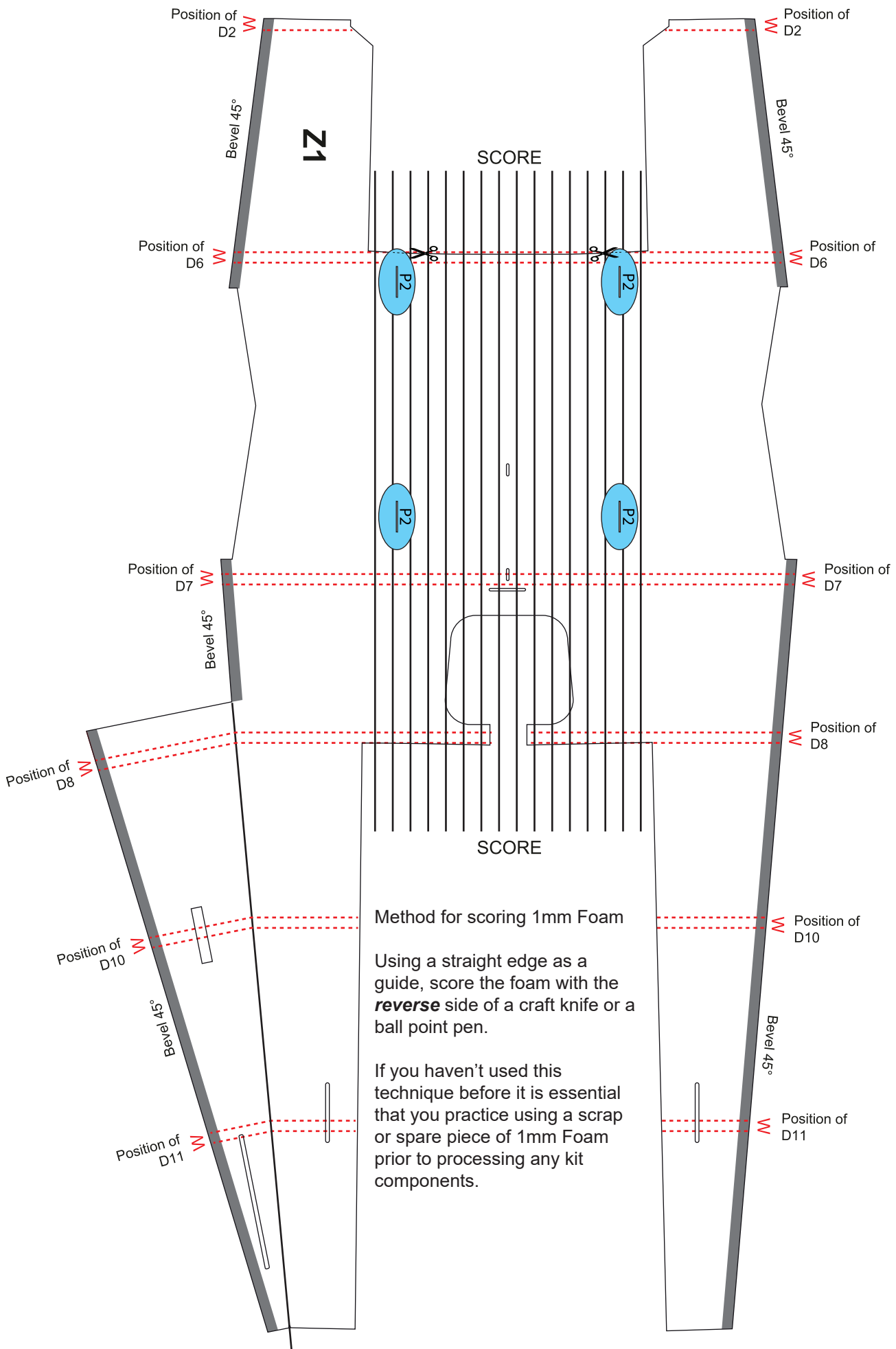

Indicates positions of fuselage formers.  
 Lightly mark positions on inside of fuselage for reference during build



## SCORING & BEVELING GUIDE #2

Method for scoring 1mm Foam

Using a straight edge as a guide, score the Foam with the **reverse** side of a craft knife or a ball point pen.

If you haven't used this technique before it is essential that you practice using a scrap or spare piece of 1mm Foam prior to processing any kit components.

! Always score on the UNPRINTED side of the Depron unless otherwise directed

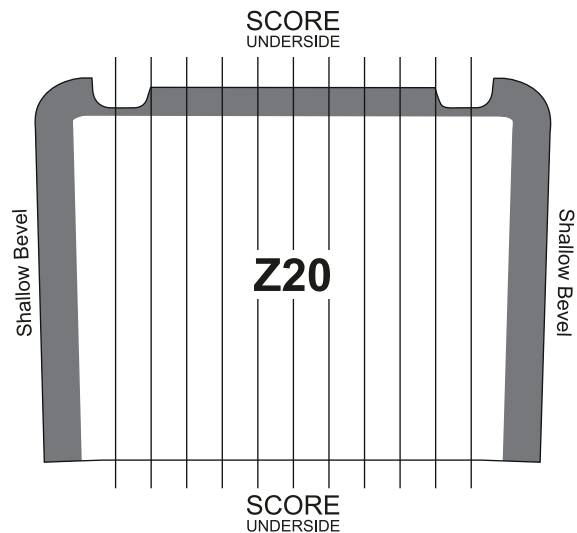
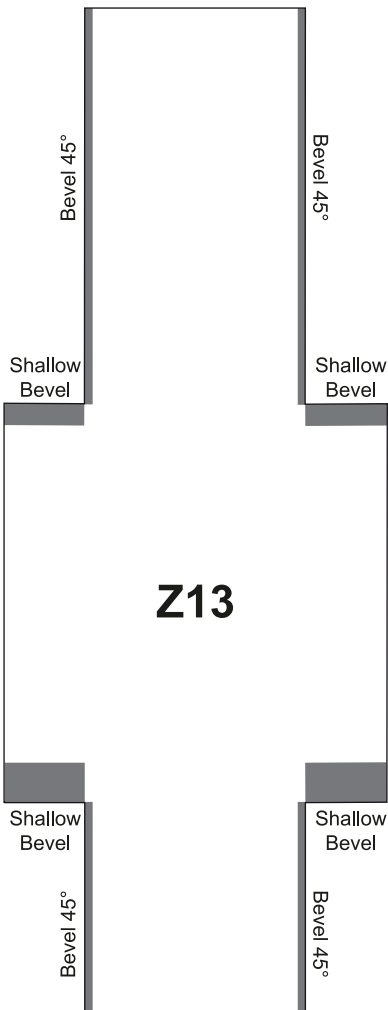
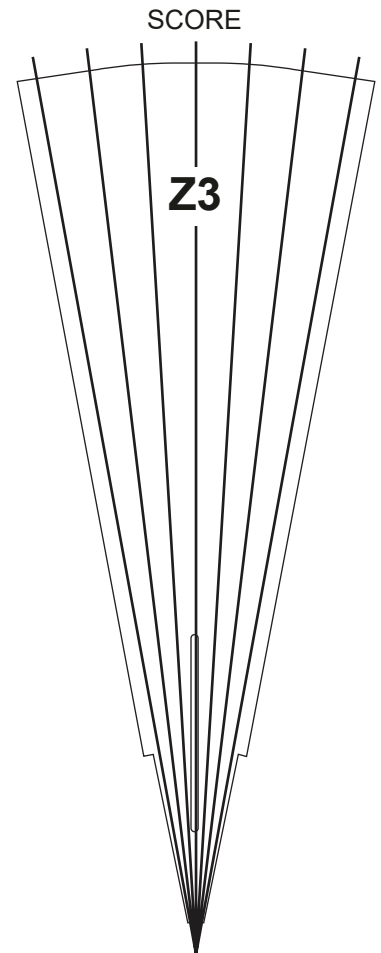
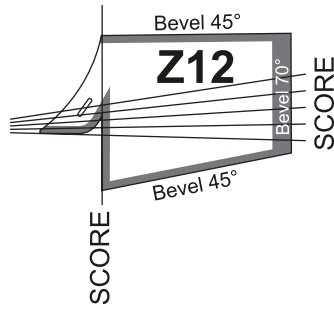

## STAGE 1 AIRFRAME



The plastic parts used in the airframe are there to increase the strength of the structure in vital areas whilst still providing some flexibility.



Apply a thin layer of adhesive to the plastic part and attach immediately to allow some wiggle time to get the parts lined up. Set aside to cure.

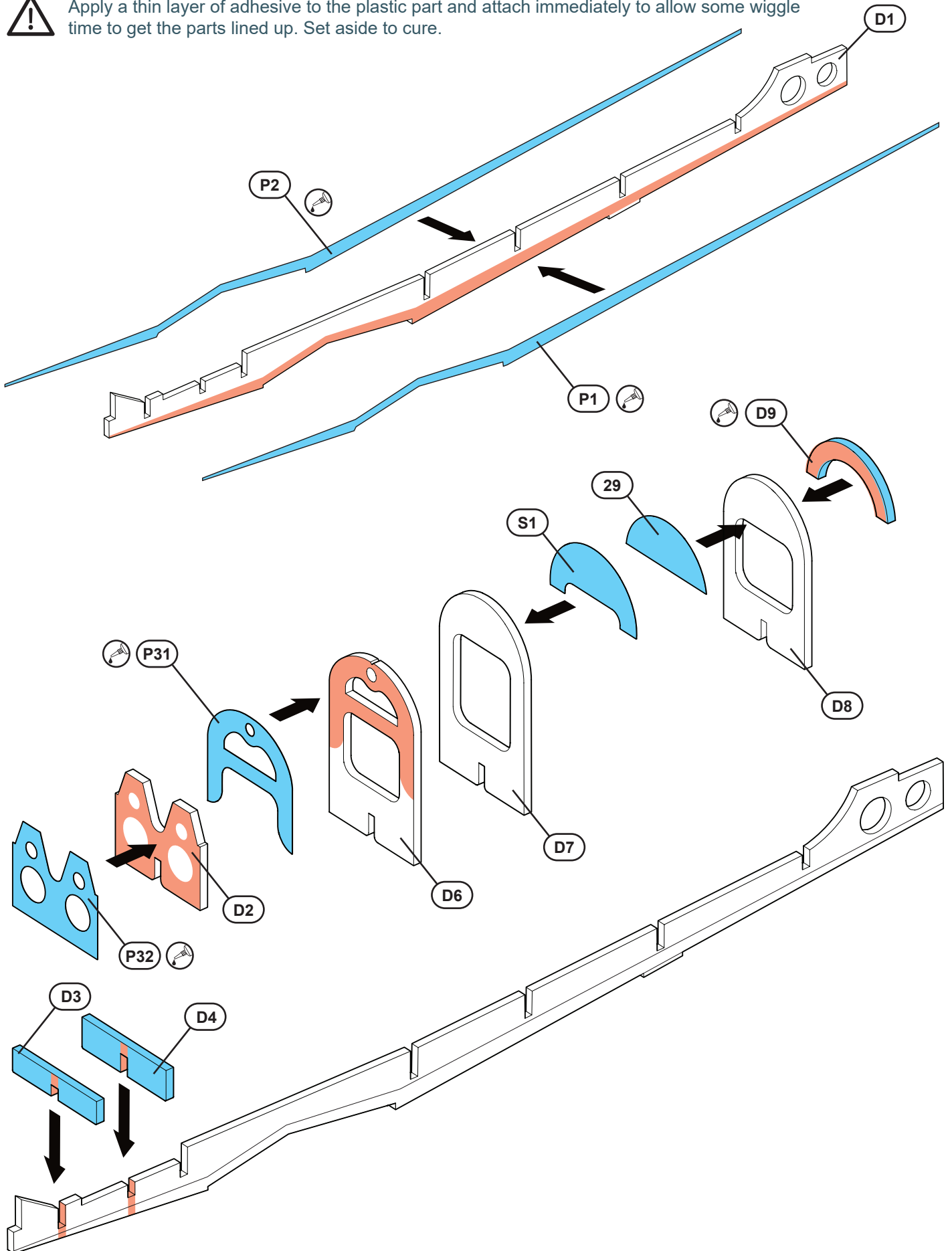

# STAGE 1 AIRFRAME

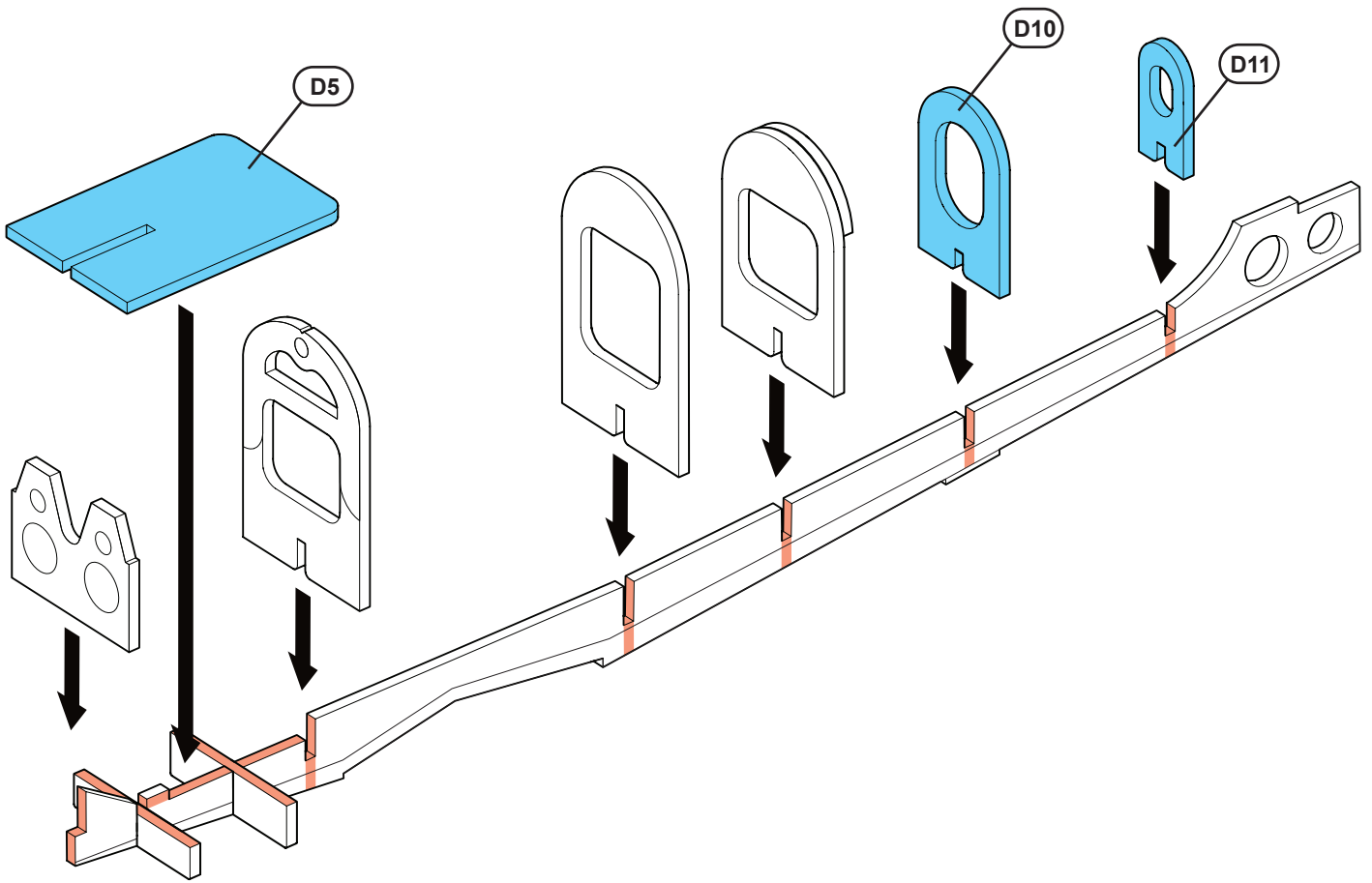

Bevel & Score before installation -  
See Scoring & Beveling guide #1

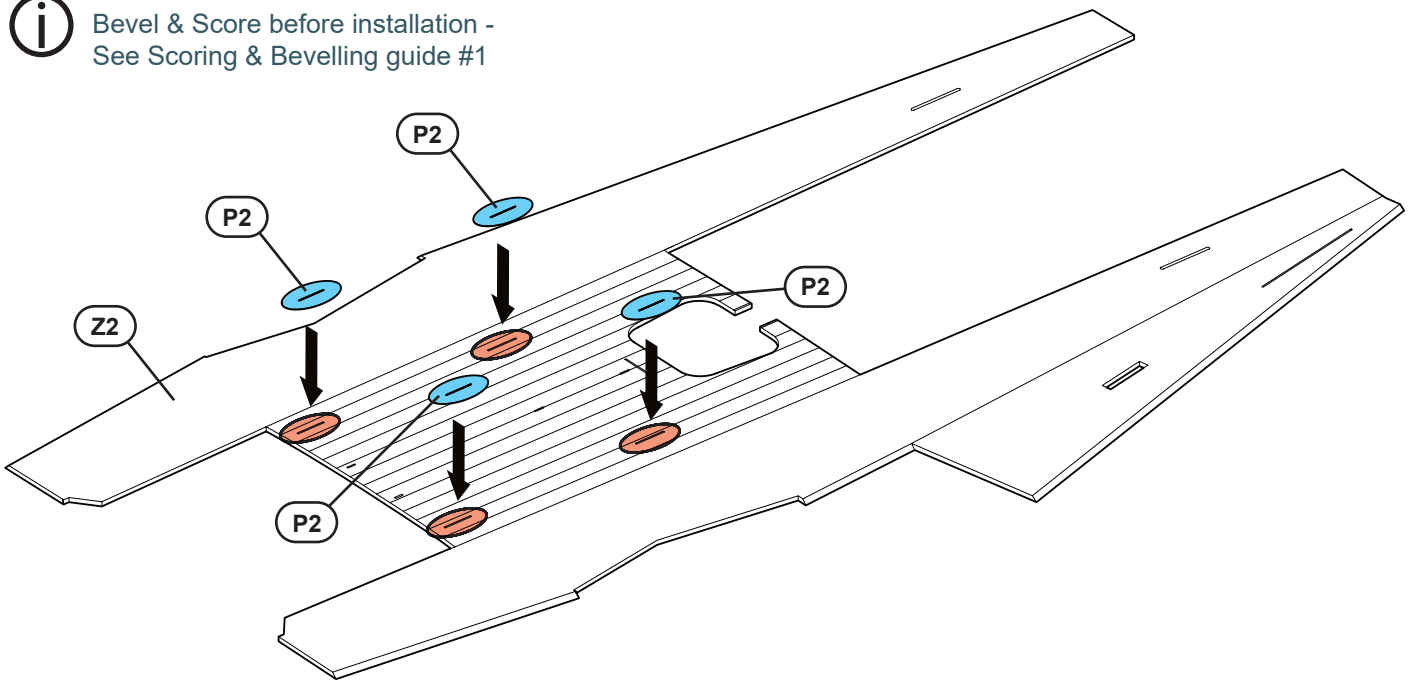

## STAGE 1 AIRFRAME

**i** Attach the fuselage skin in stages, checking at each stage that alignment is good. Don't forget, you can always dissolve UHU por with naphtha (lighter fluid) applied to joins with a small hobbyists paint brush if you want to start over!

**i** Bevel & Score before installation - See Scoring & Beveling guide #1

**!** Always Dry fit before gluing

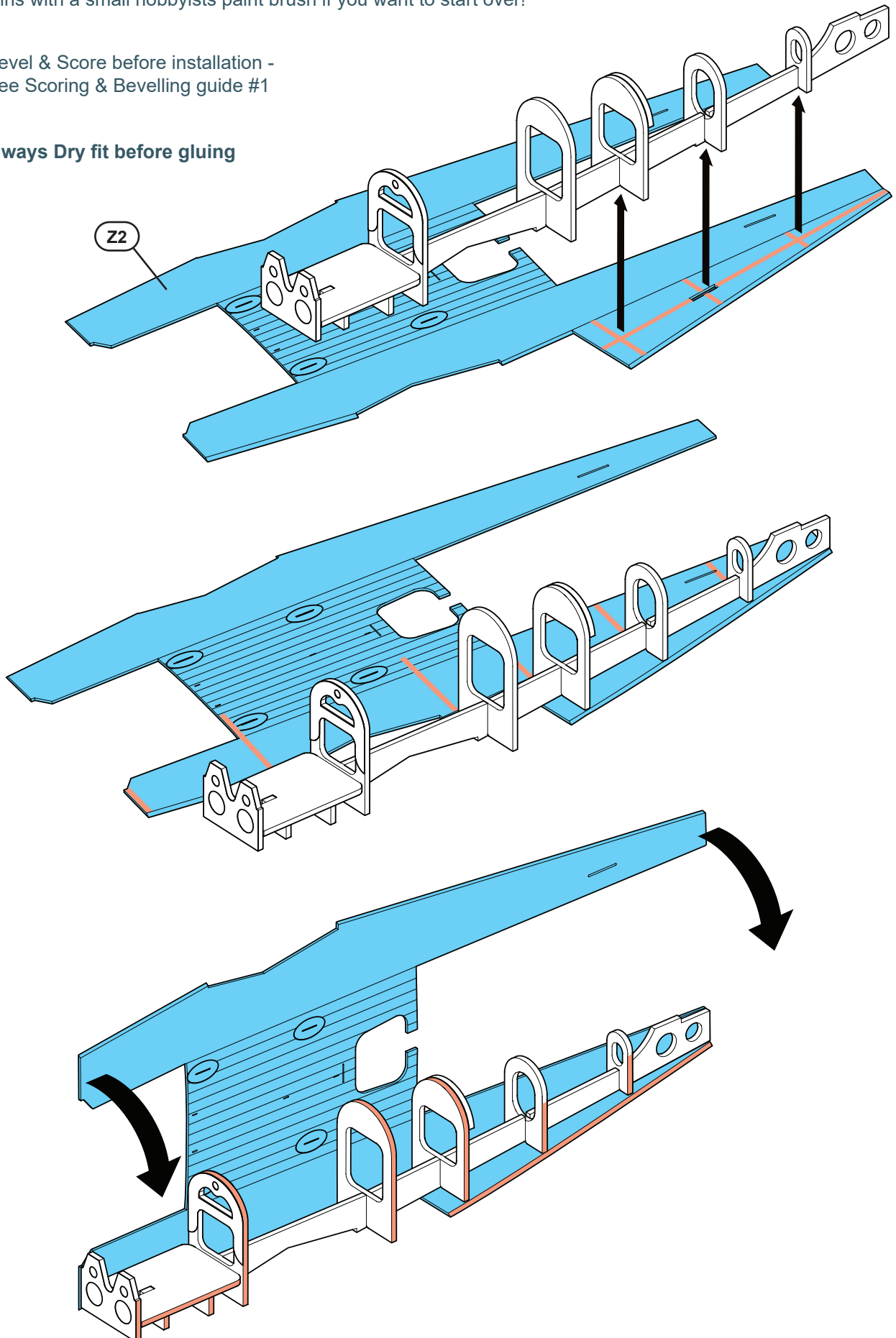

## STAGE 1 AIRFRAME

**i** Score before installation -  
See Scoring & Beveling guide #2

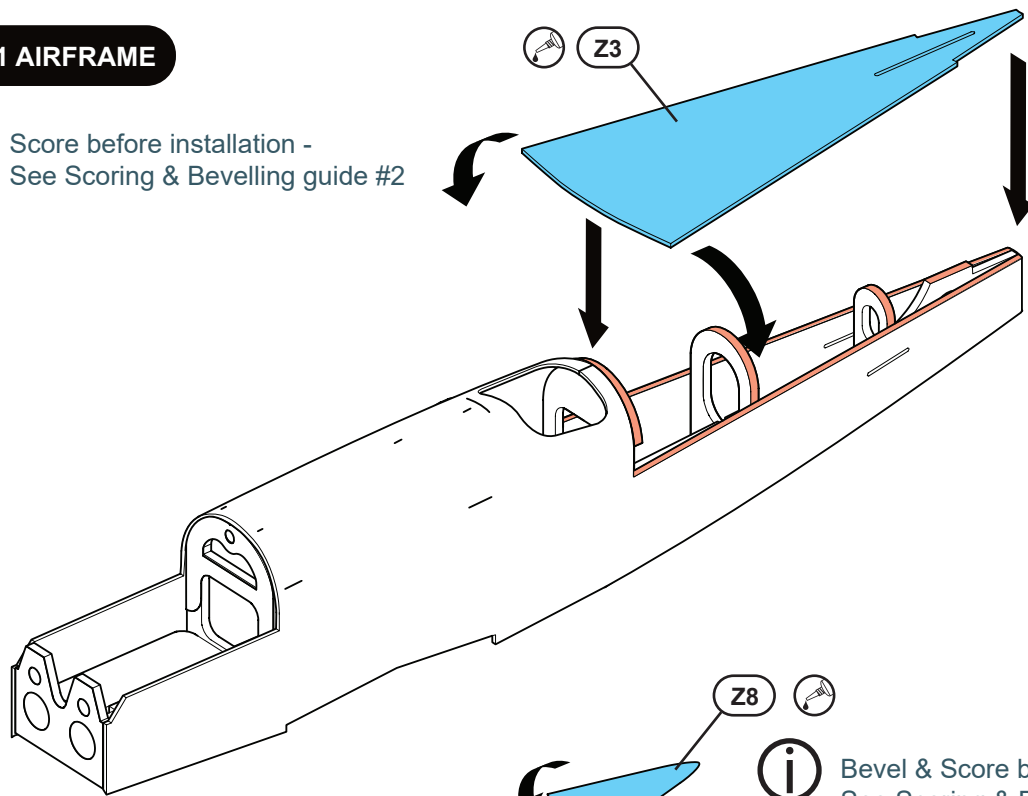

**i** Bevel & Score before installation -  
See Scoring & Beveling guide #2

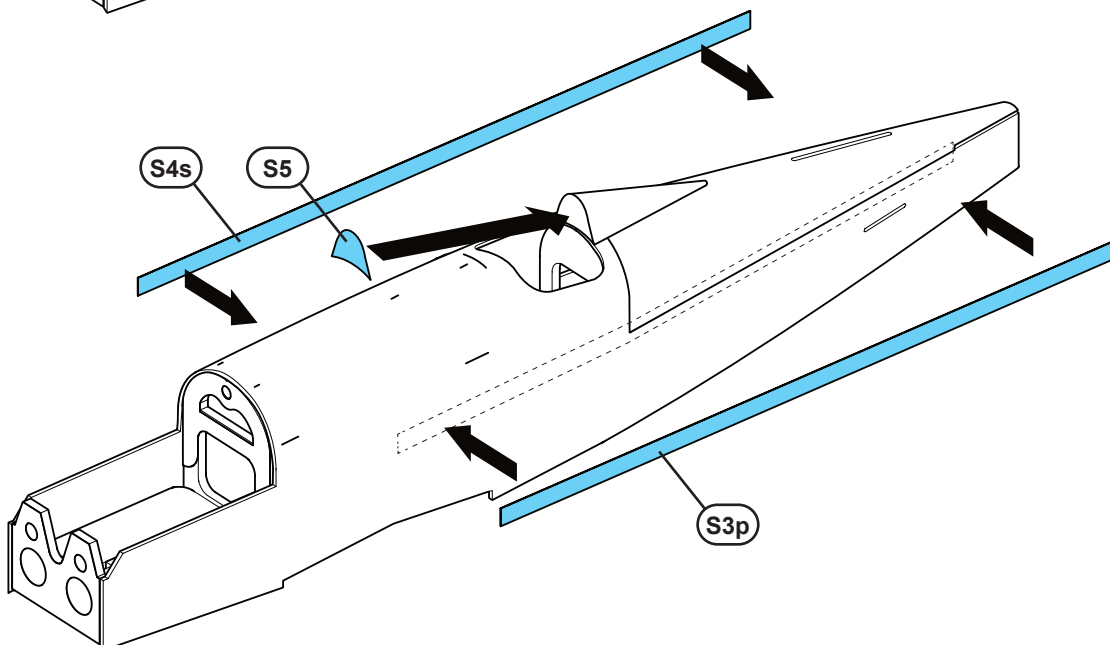
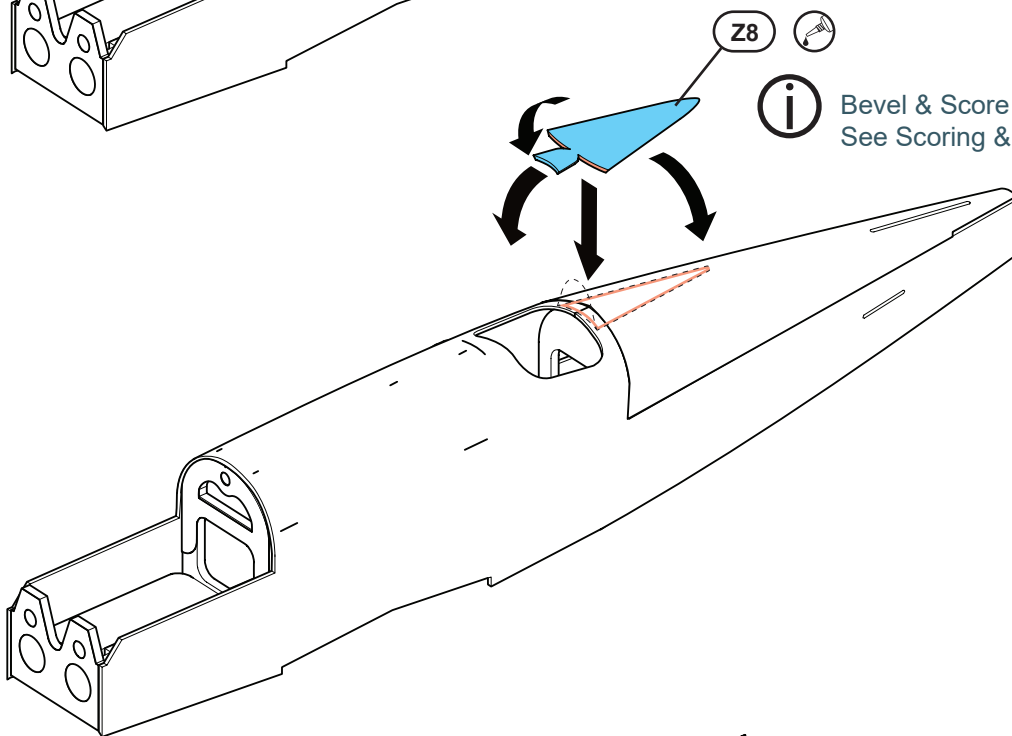

**STAGE 2 TAIL**

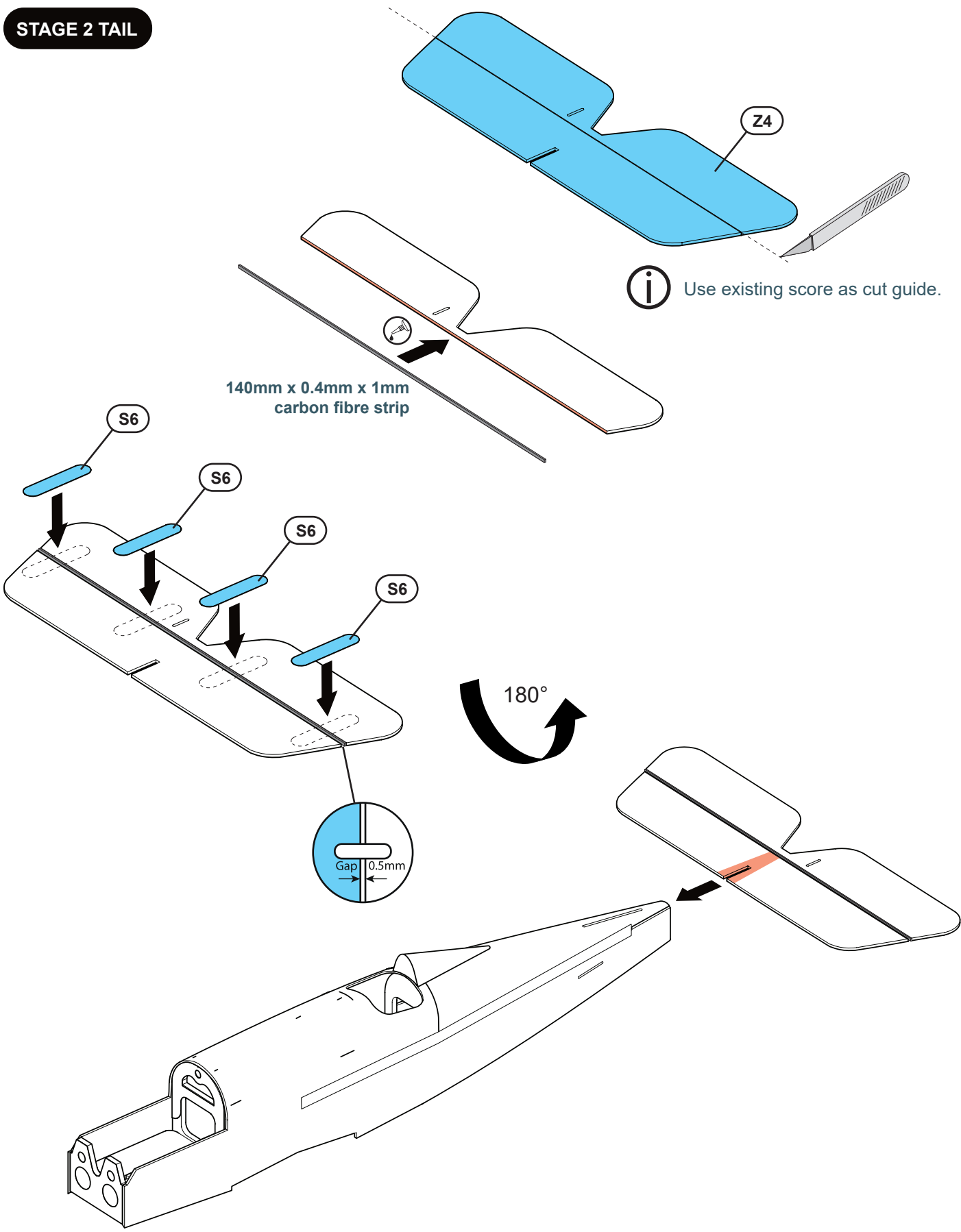

**STAGE 2 TAIL**

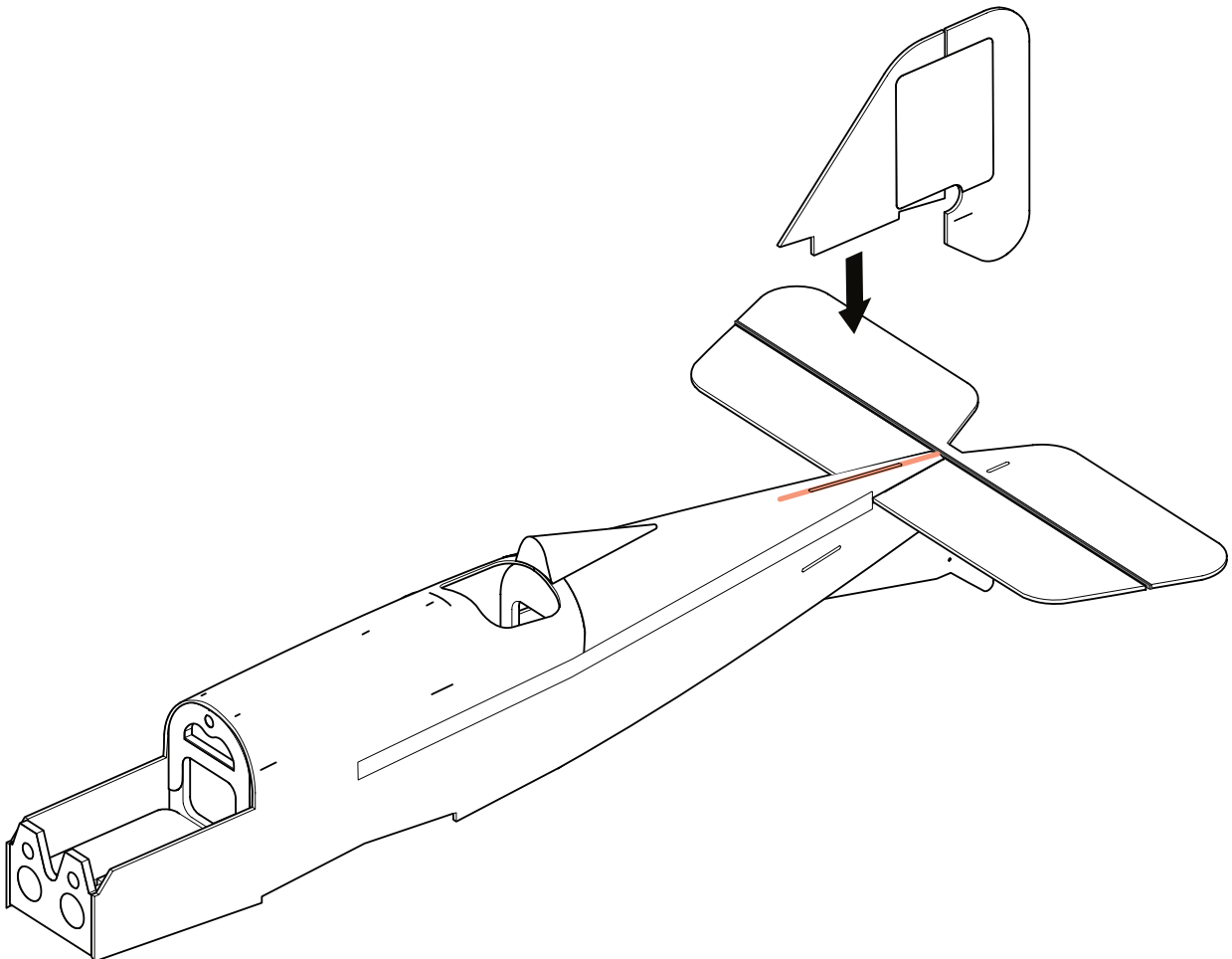
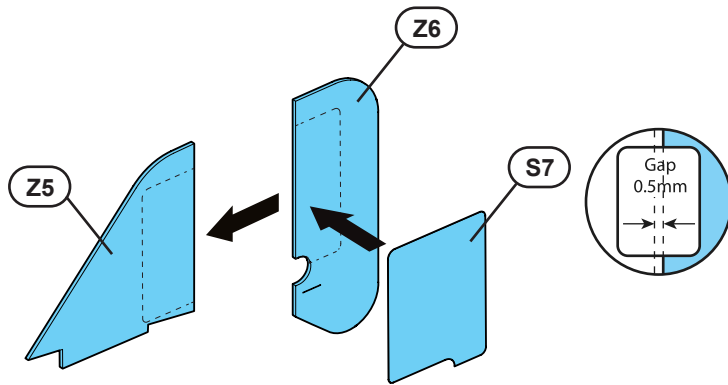
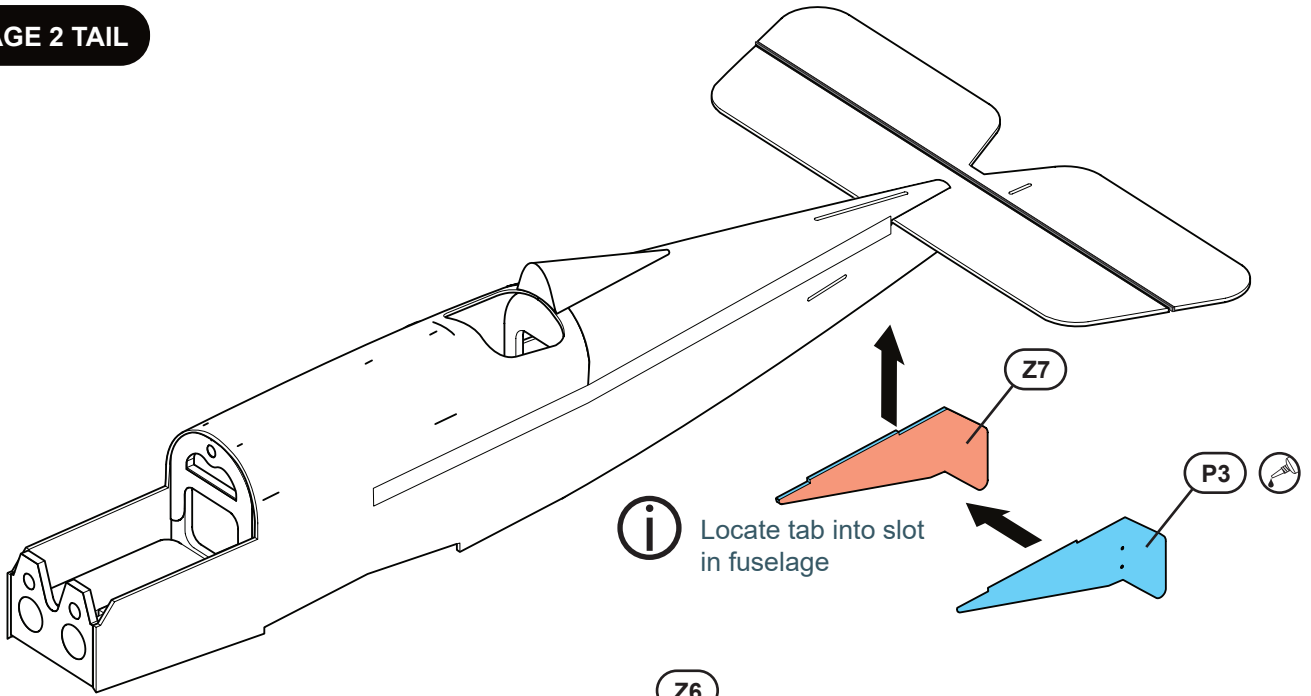

**STAGE 3 DETAIL**

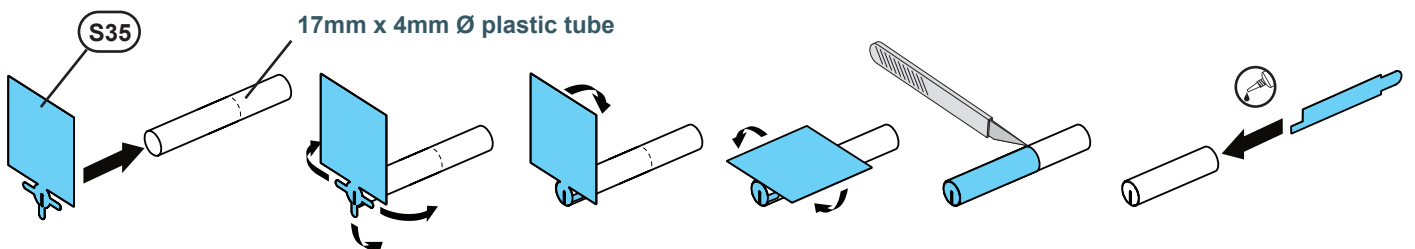
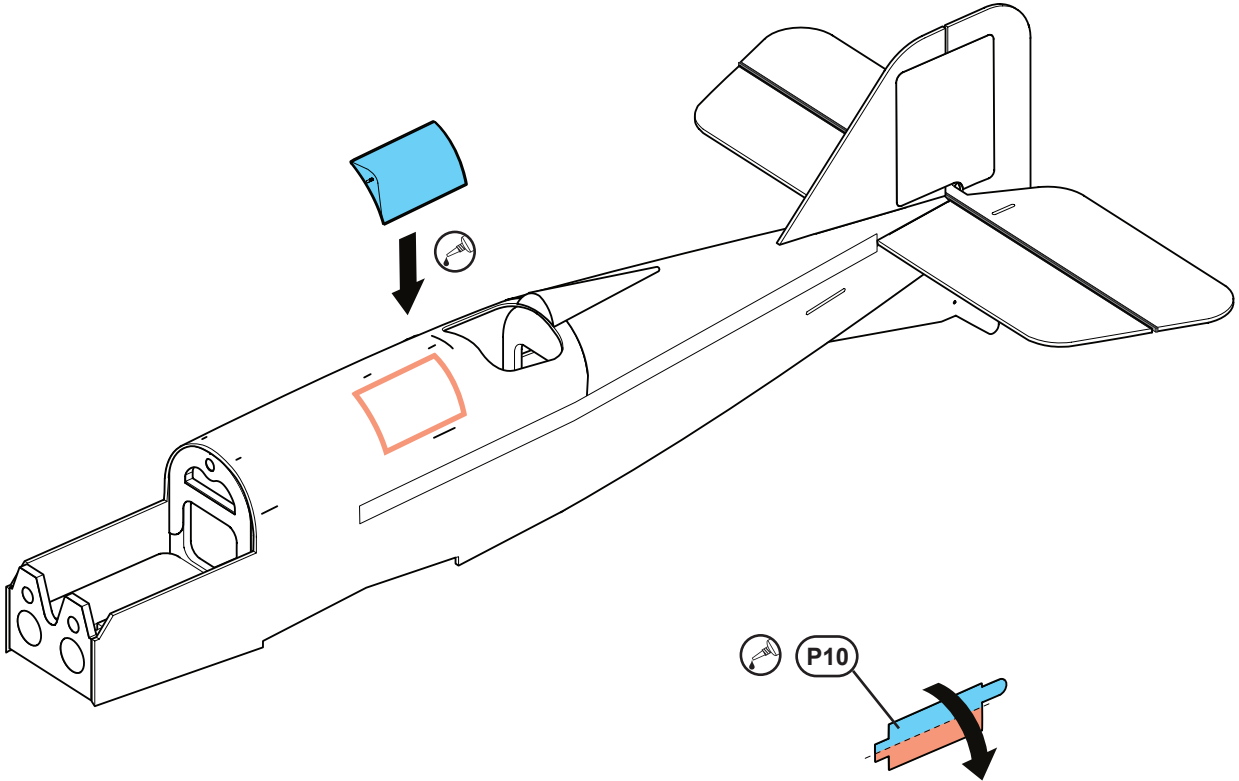
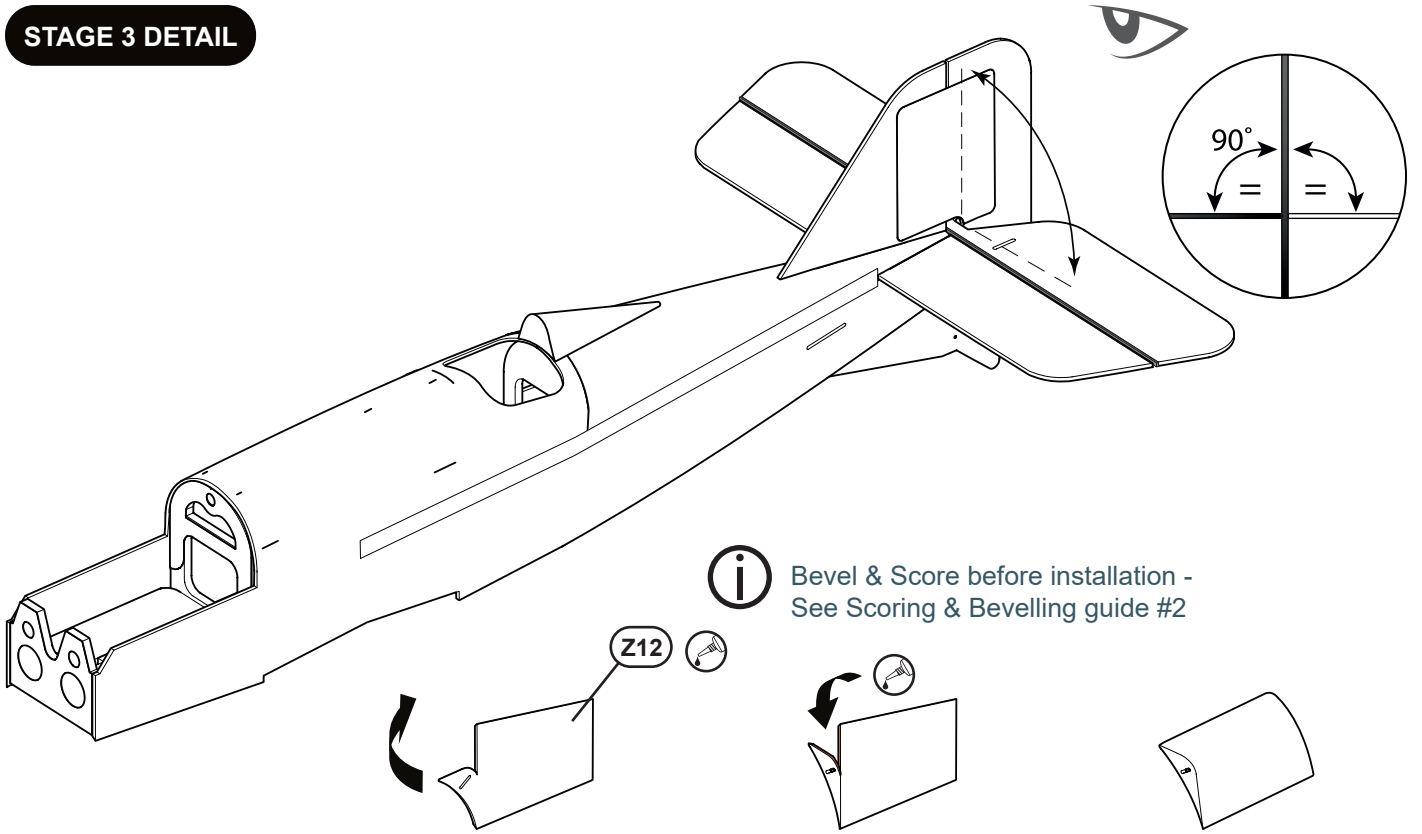



**STAGE 3 DETAIL**

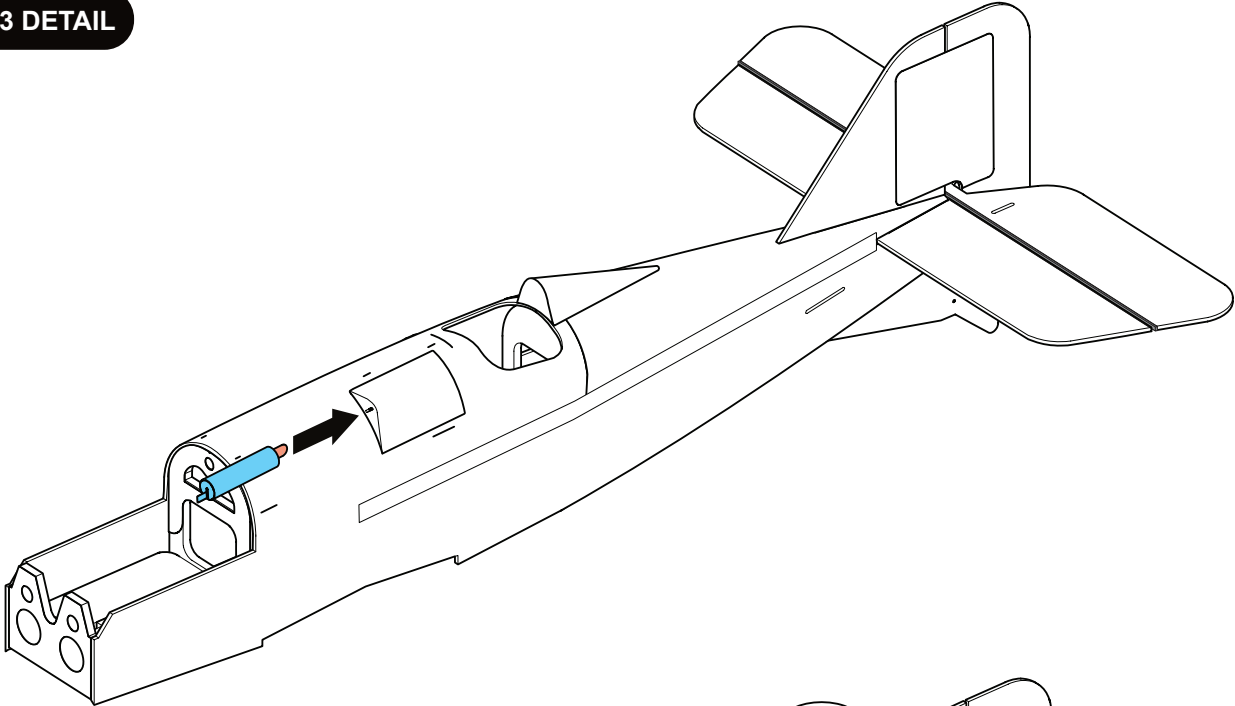

 P25

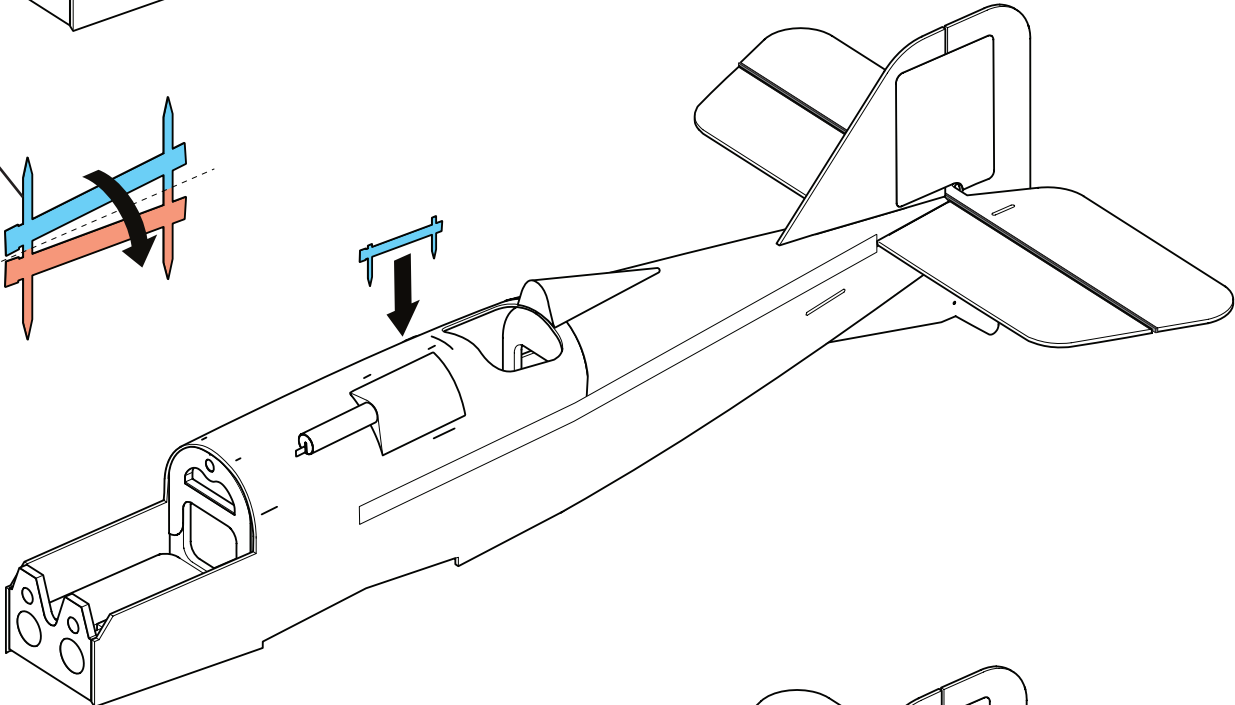
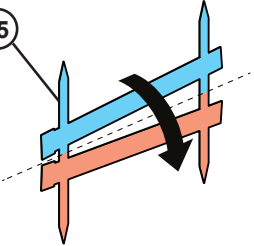

S21

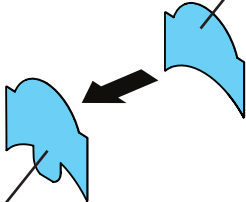

P26

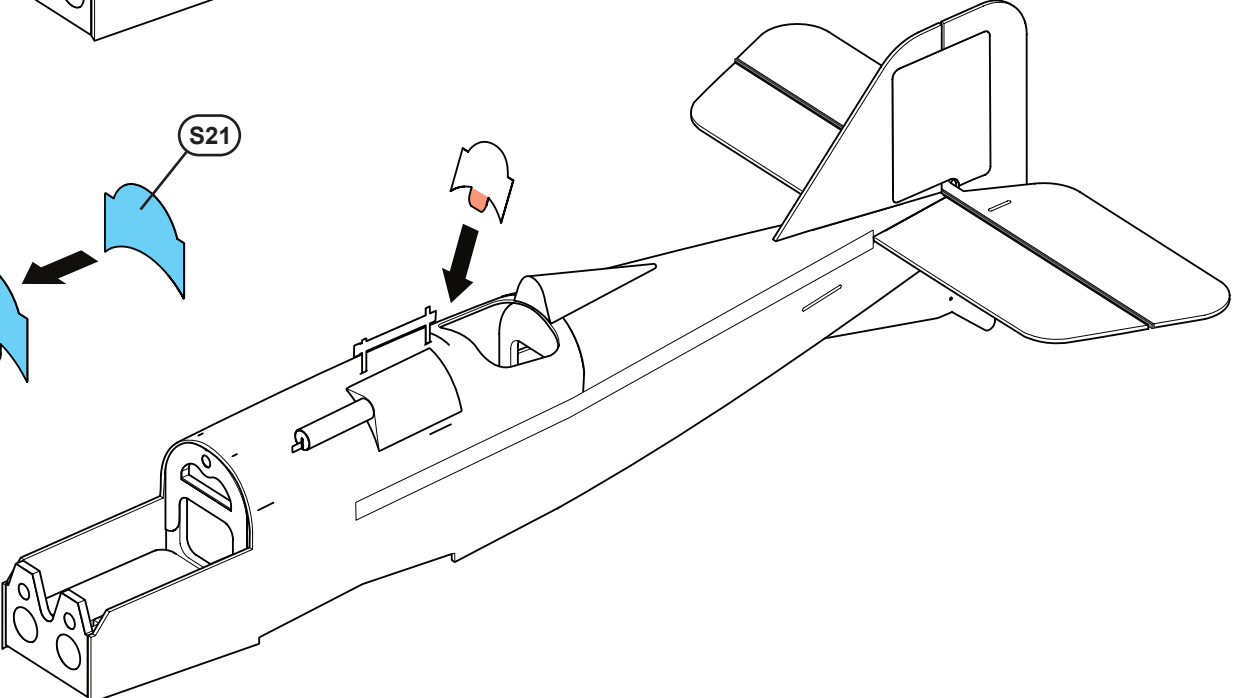

**STAGE 4 LOWER WING**

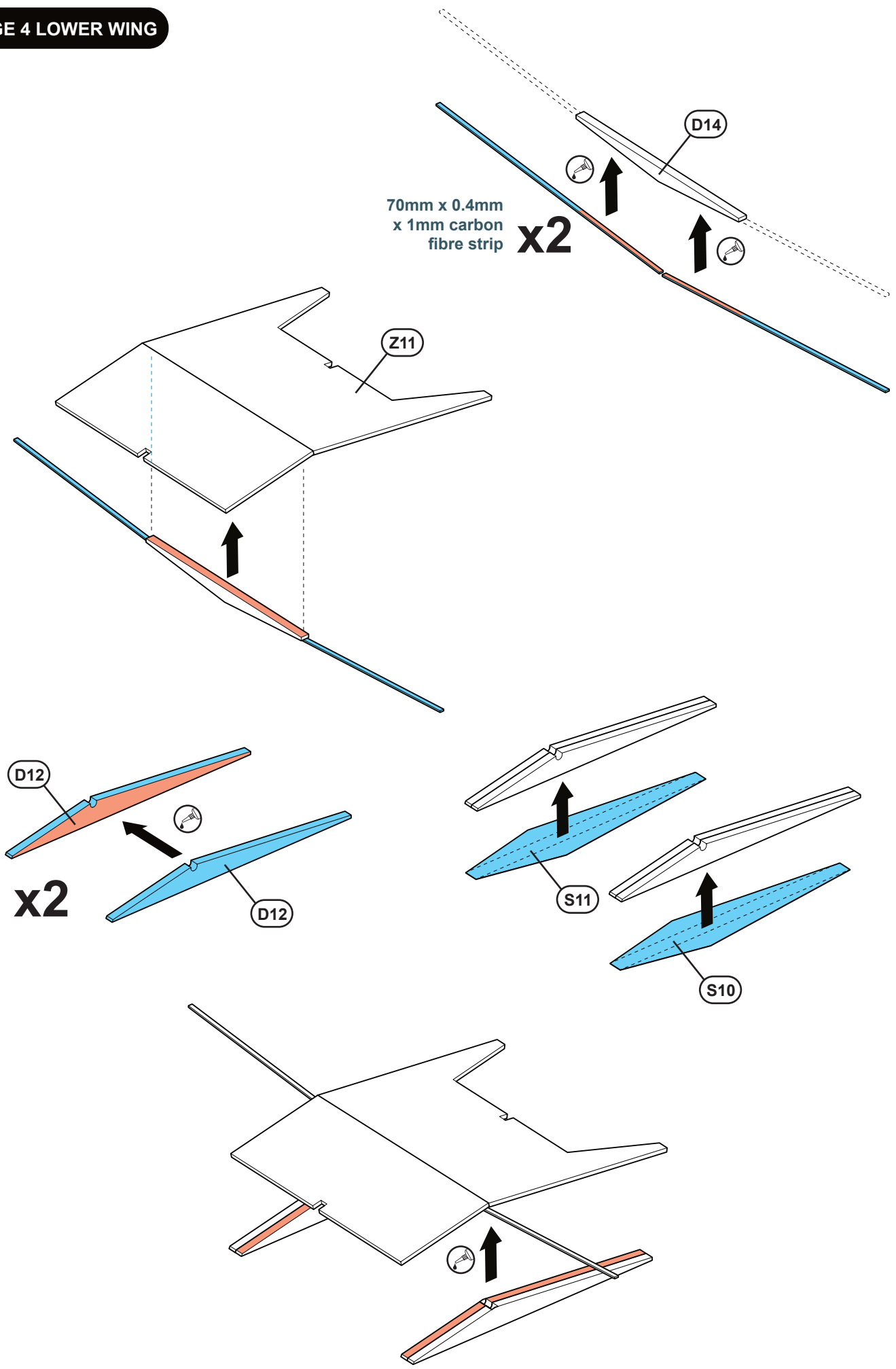

**STAGE 4 LOWER WING**

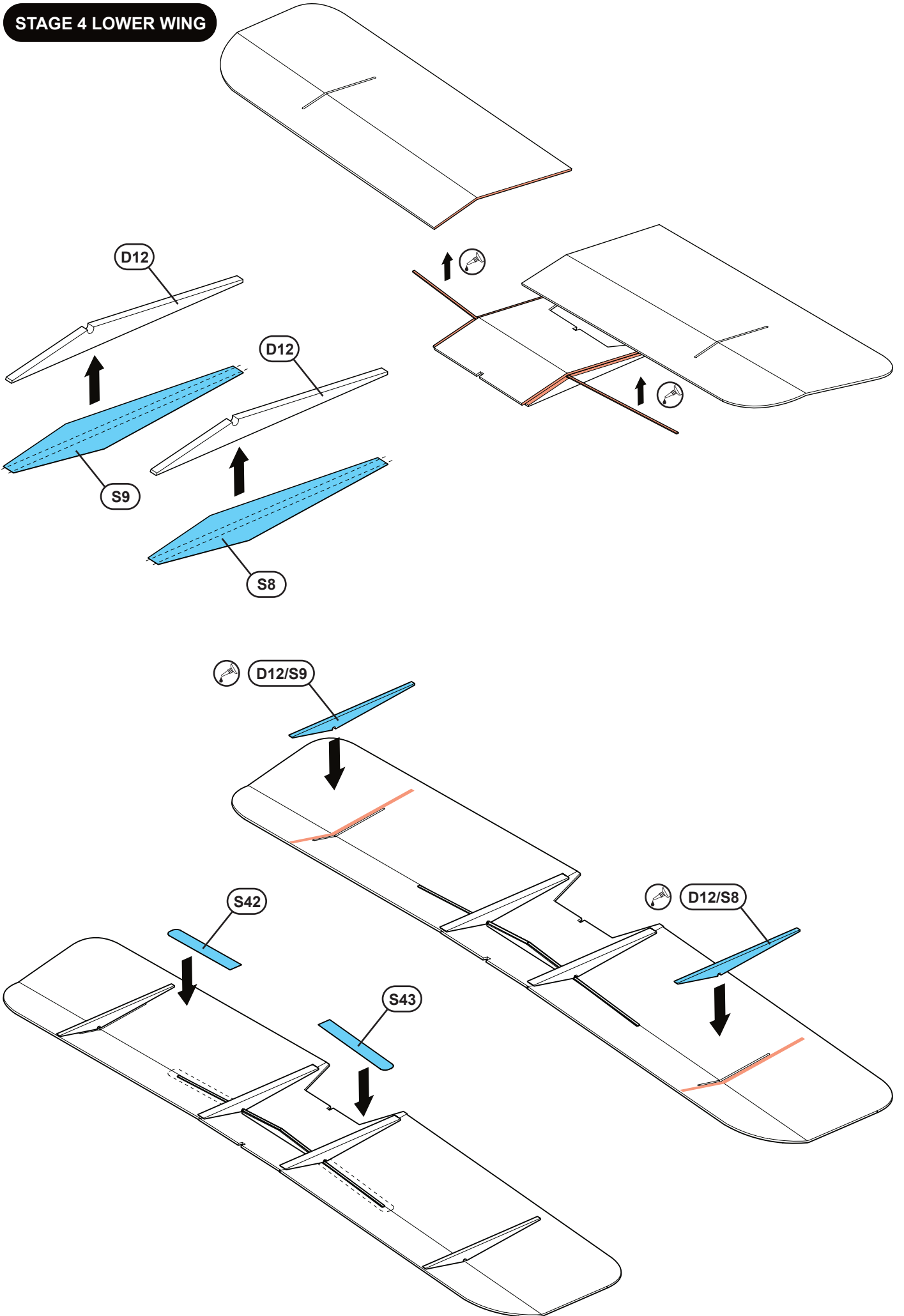

**STAGE 4 LOWER WING**

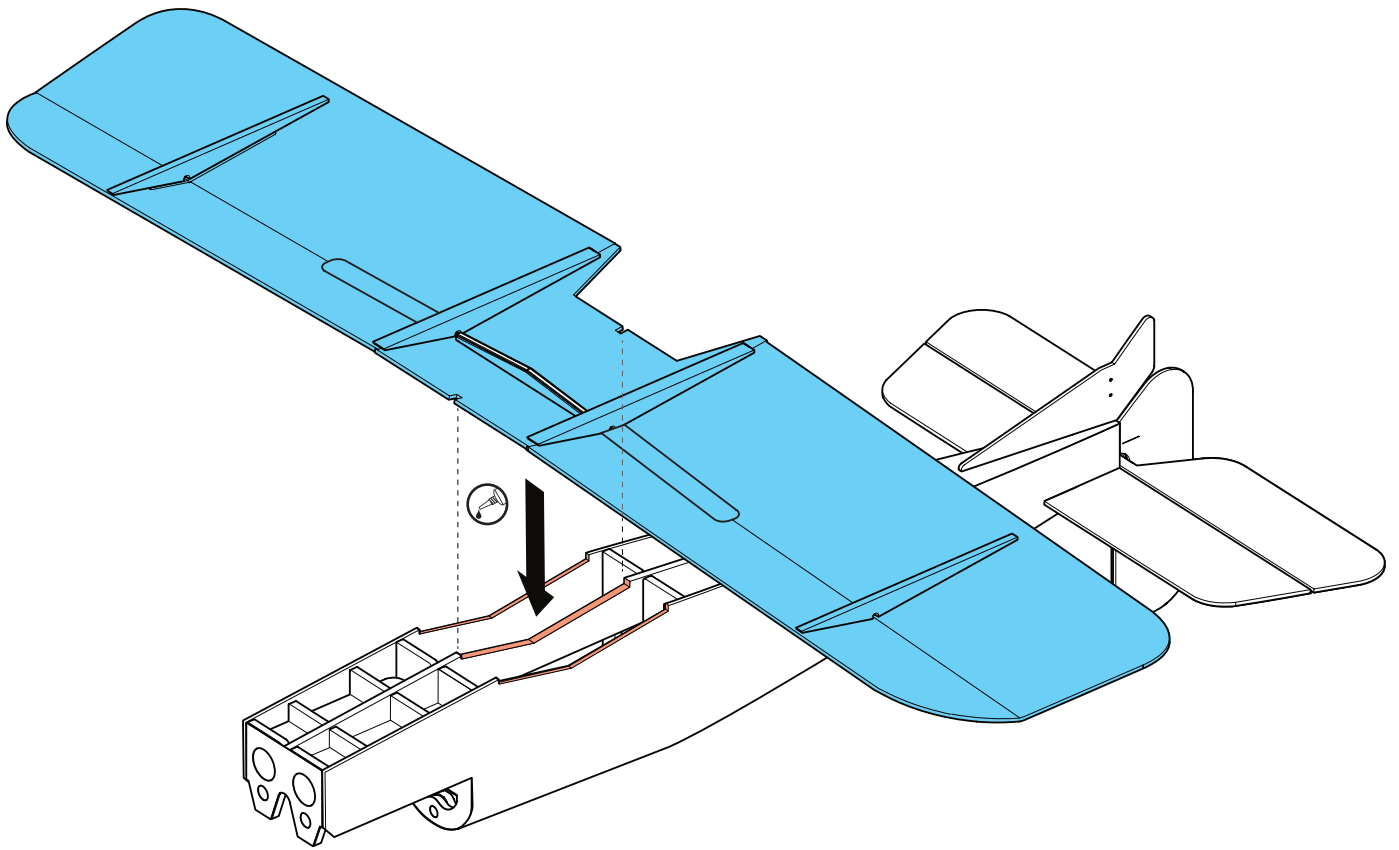

**i** Bevel before installation -  
See Scoring & Beveling guide #2

Z13

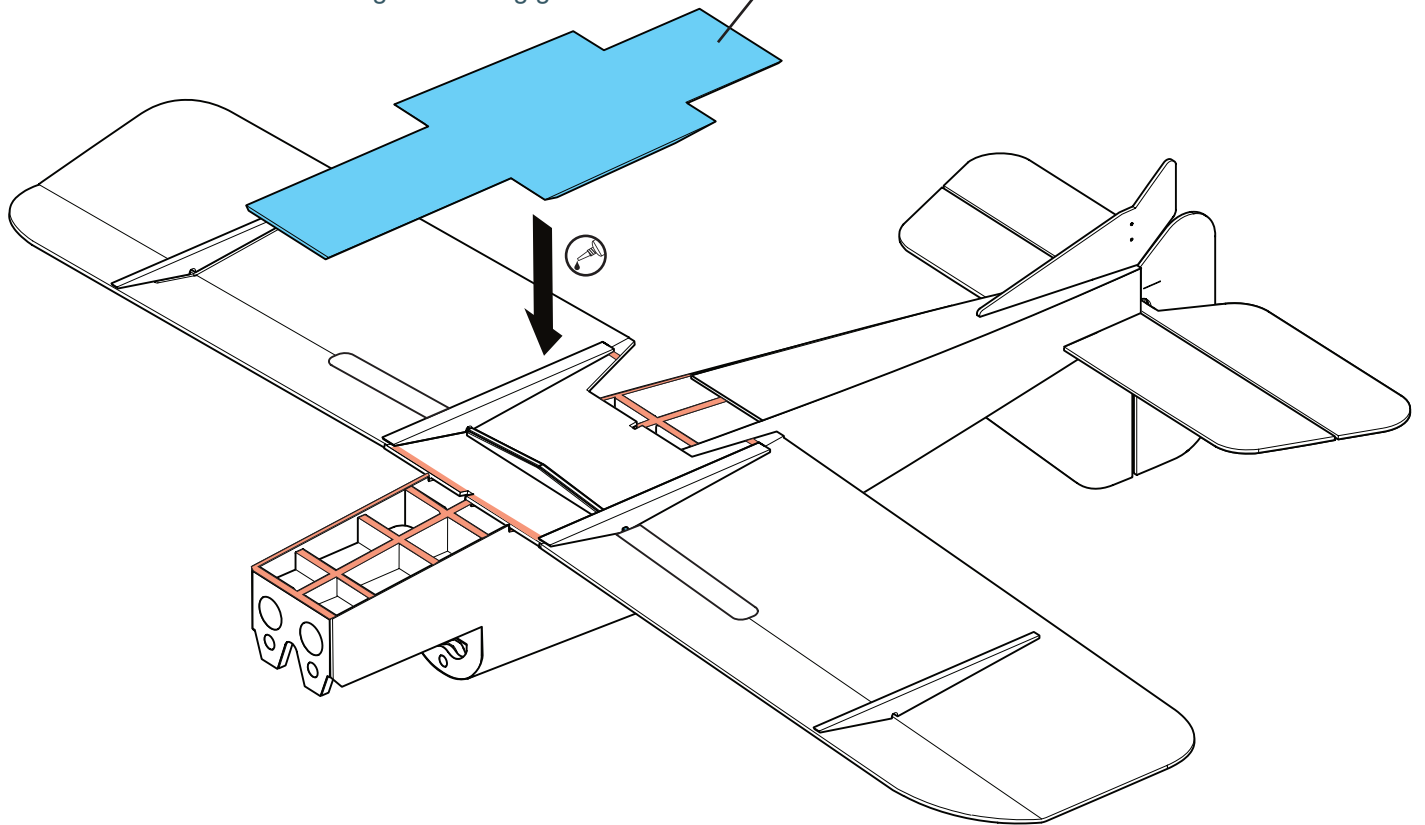

# STAGE 5 UNDERCARRIAGE

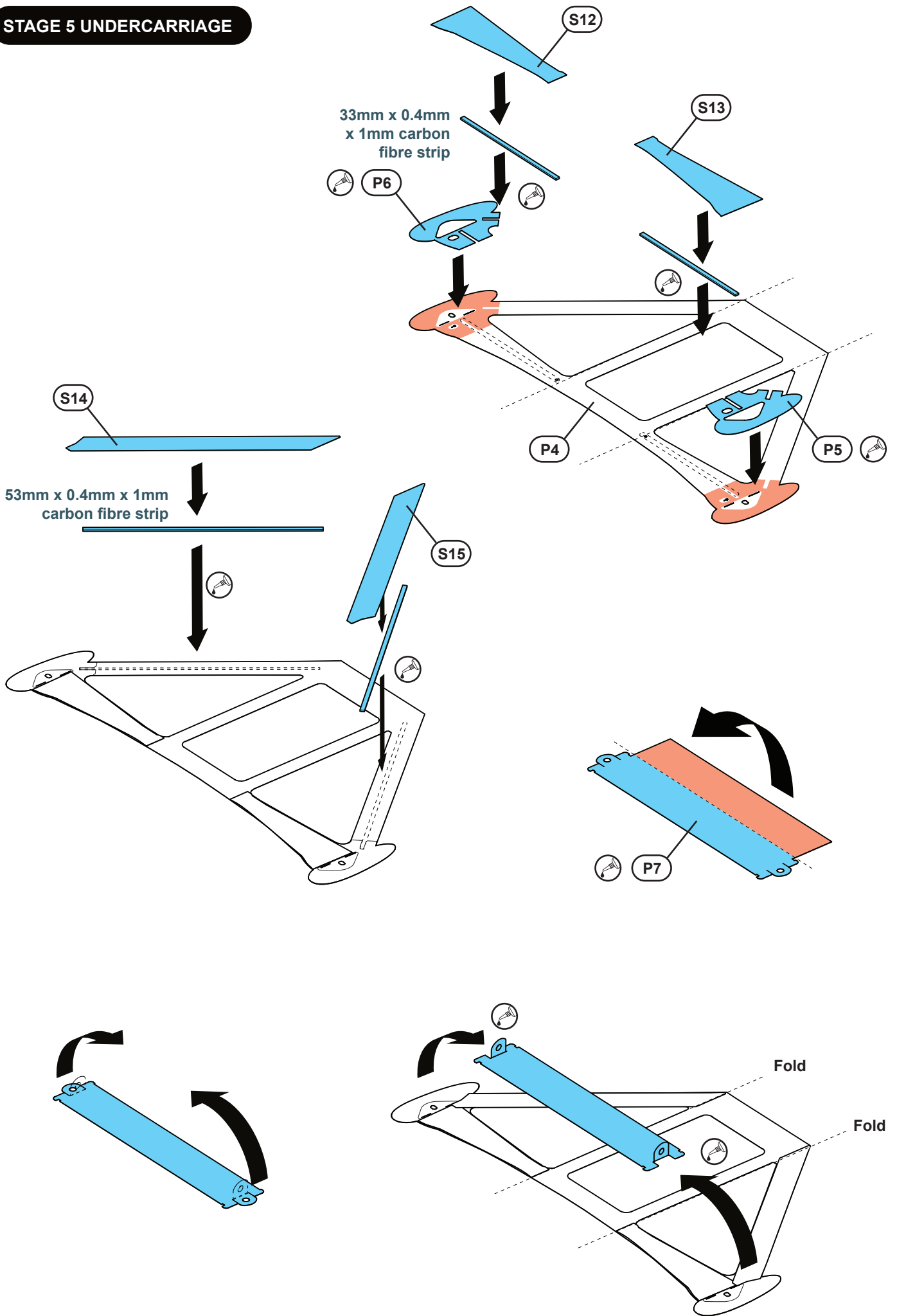

## STAGE 5 UNDERCARRIAGE

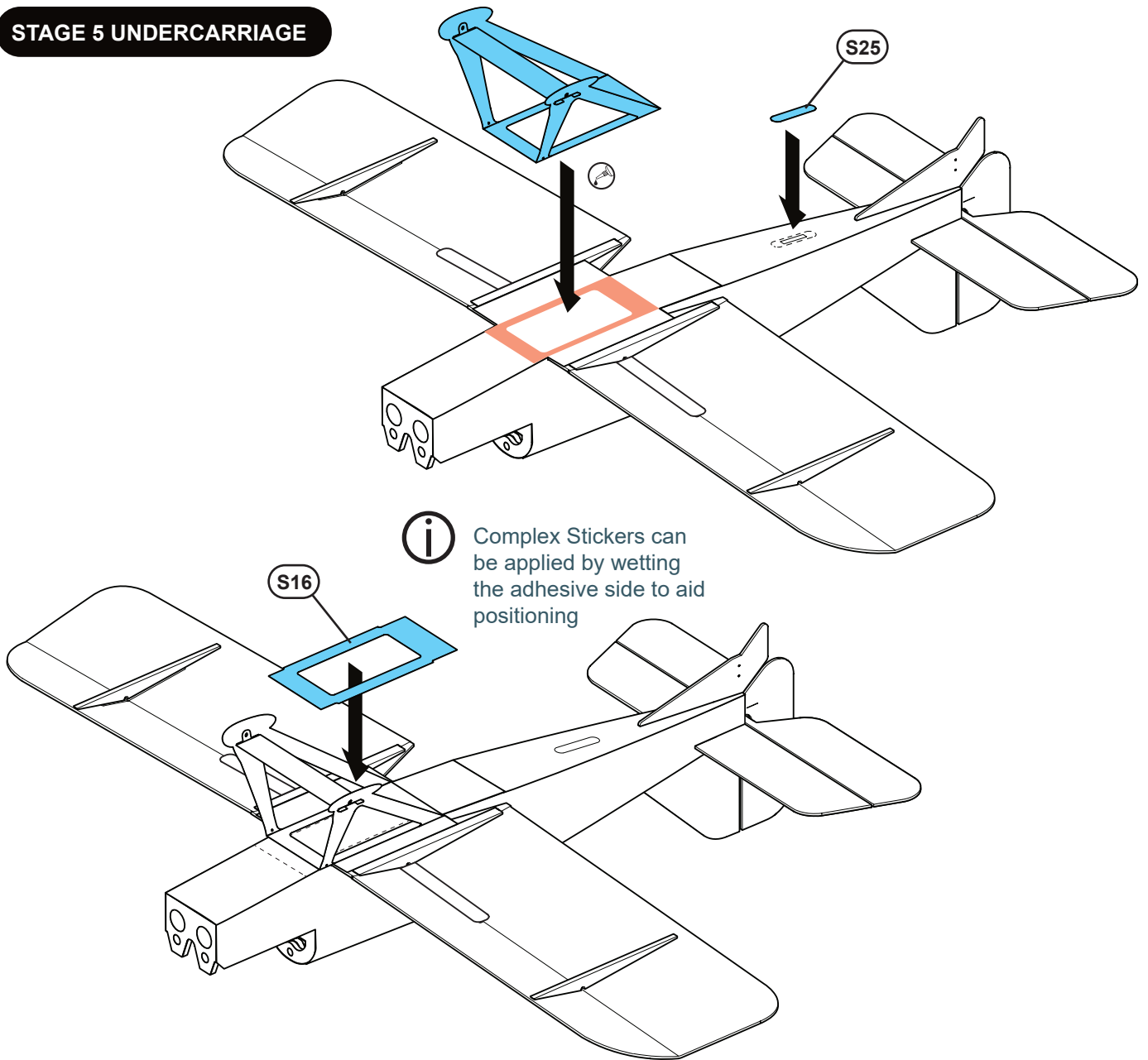

## STAGE 6 STRUTS

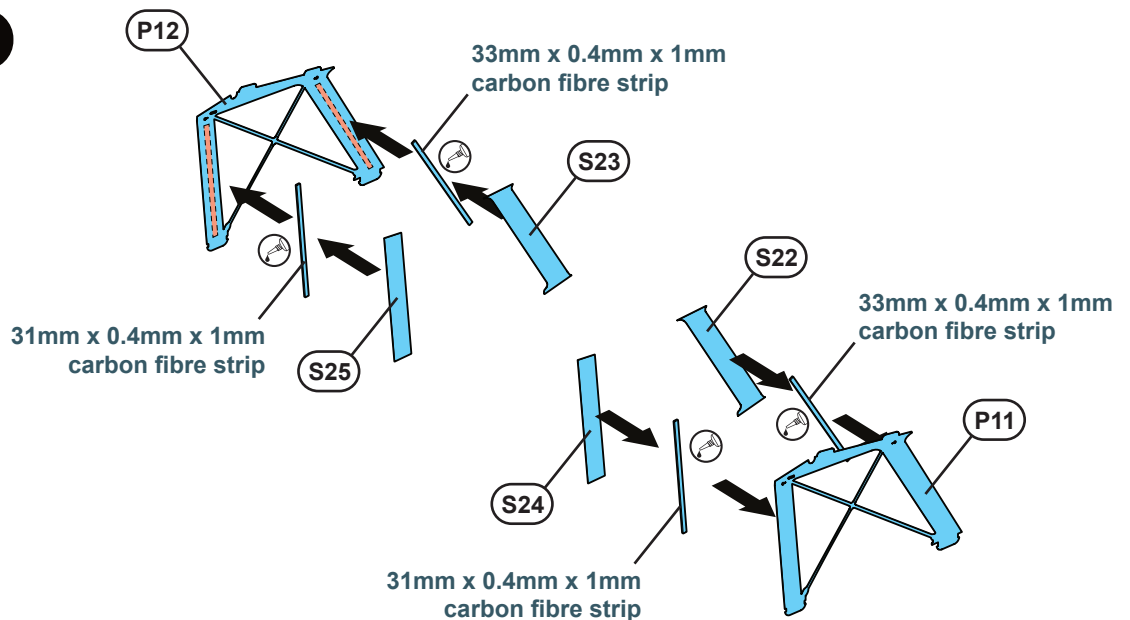

# STAGE 6 STRUTS

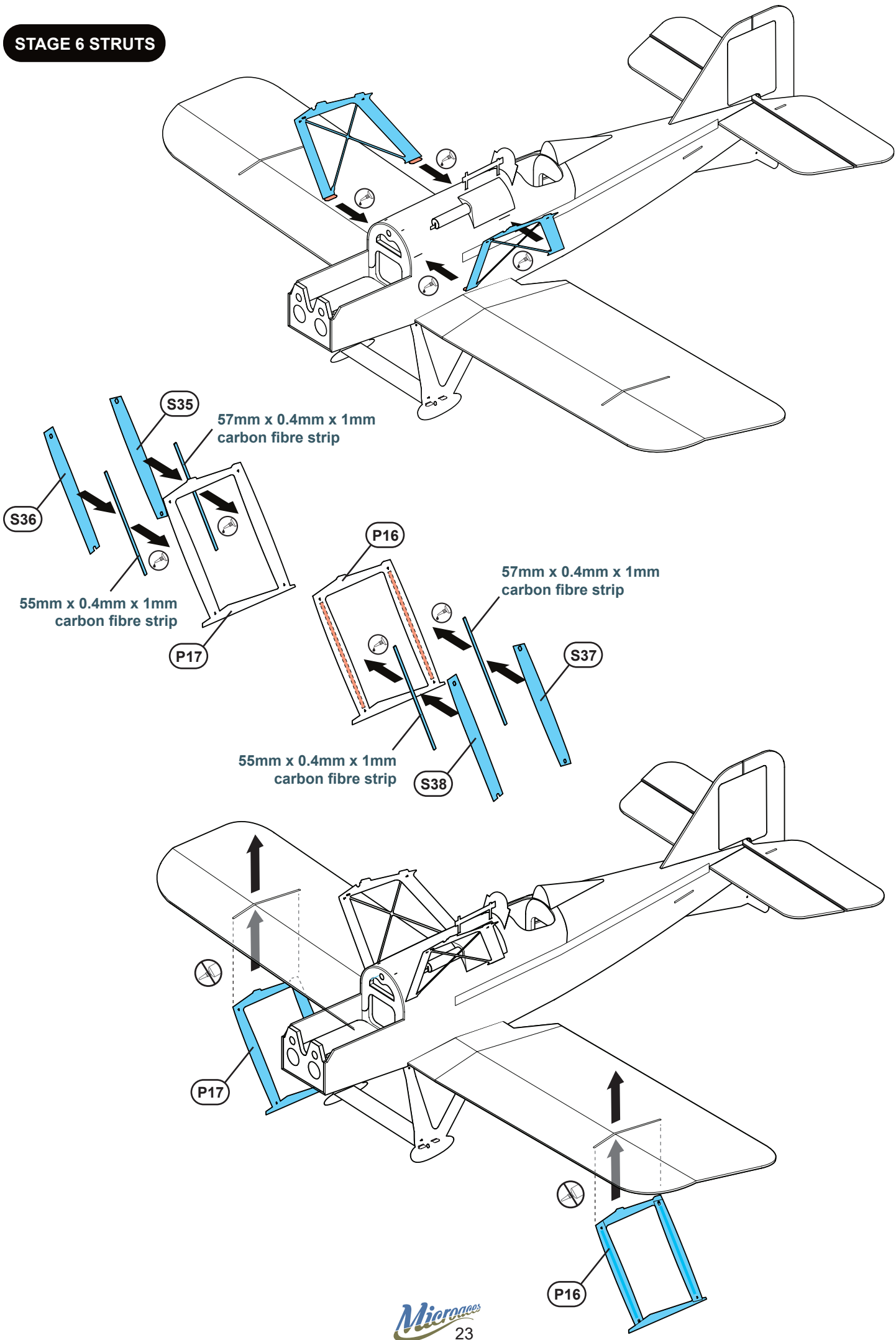

**STAGE 7 RIGGING**

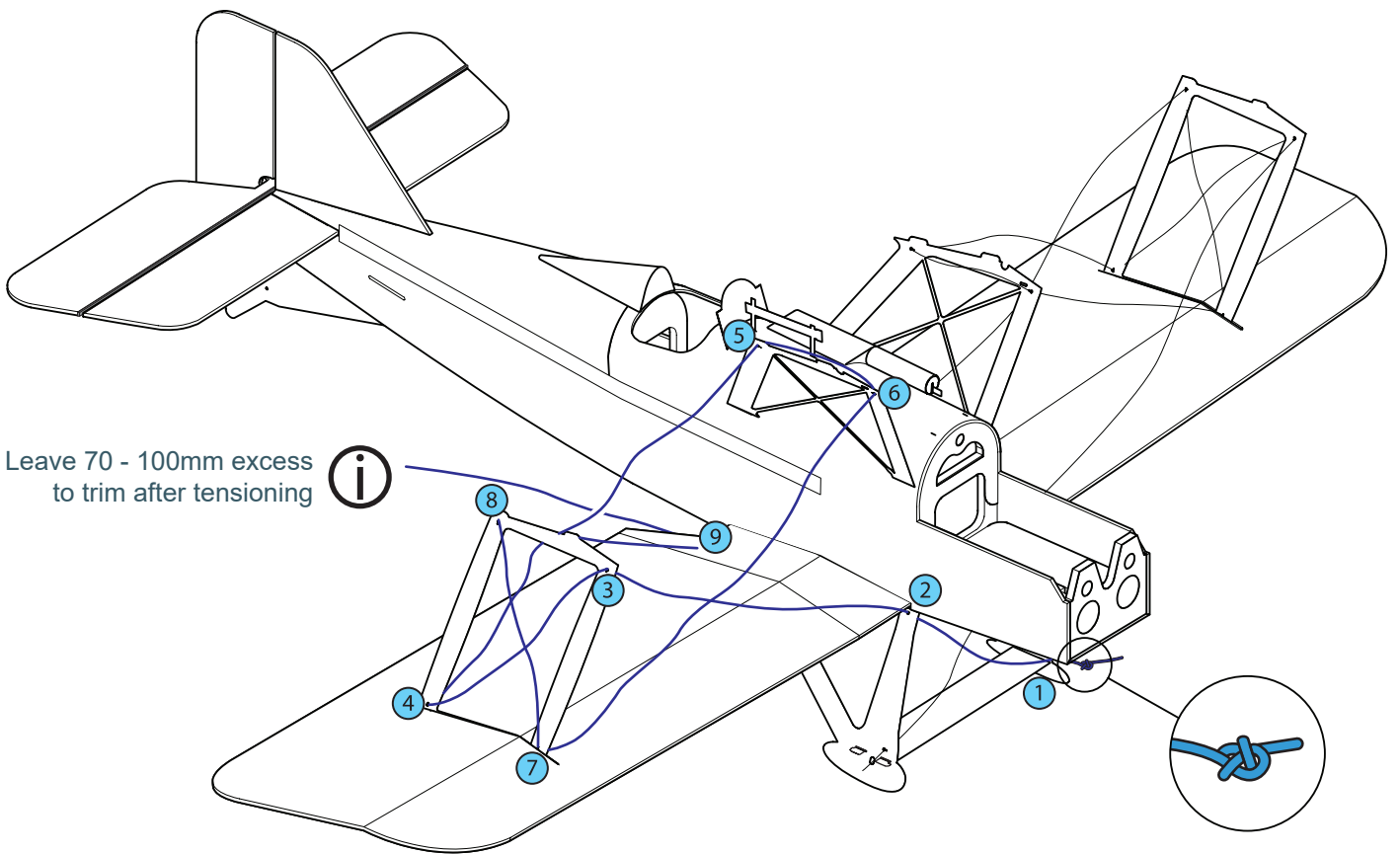
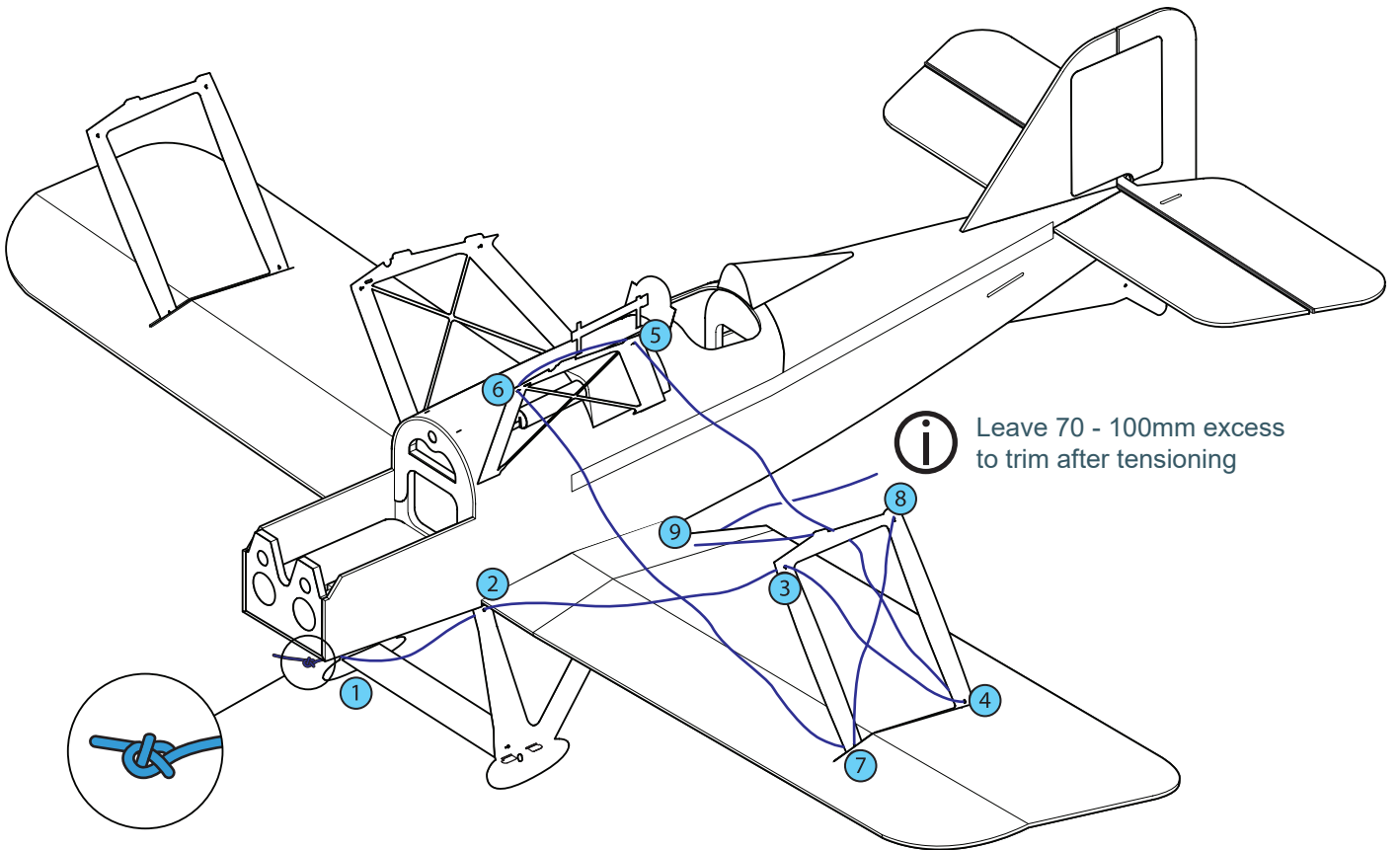



STAGE 8 UPPER WING

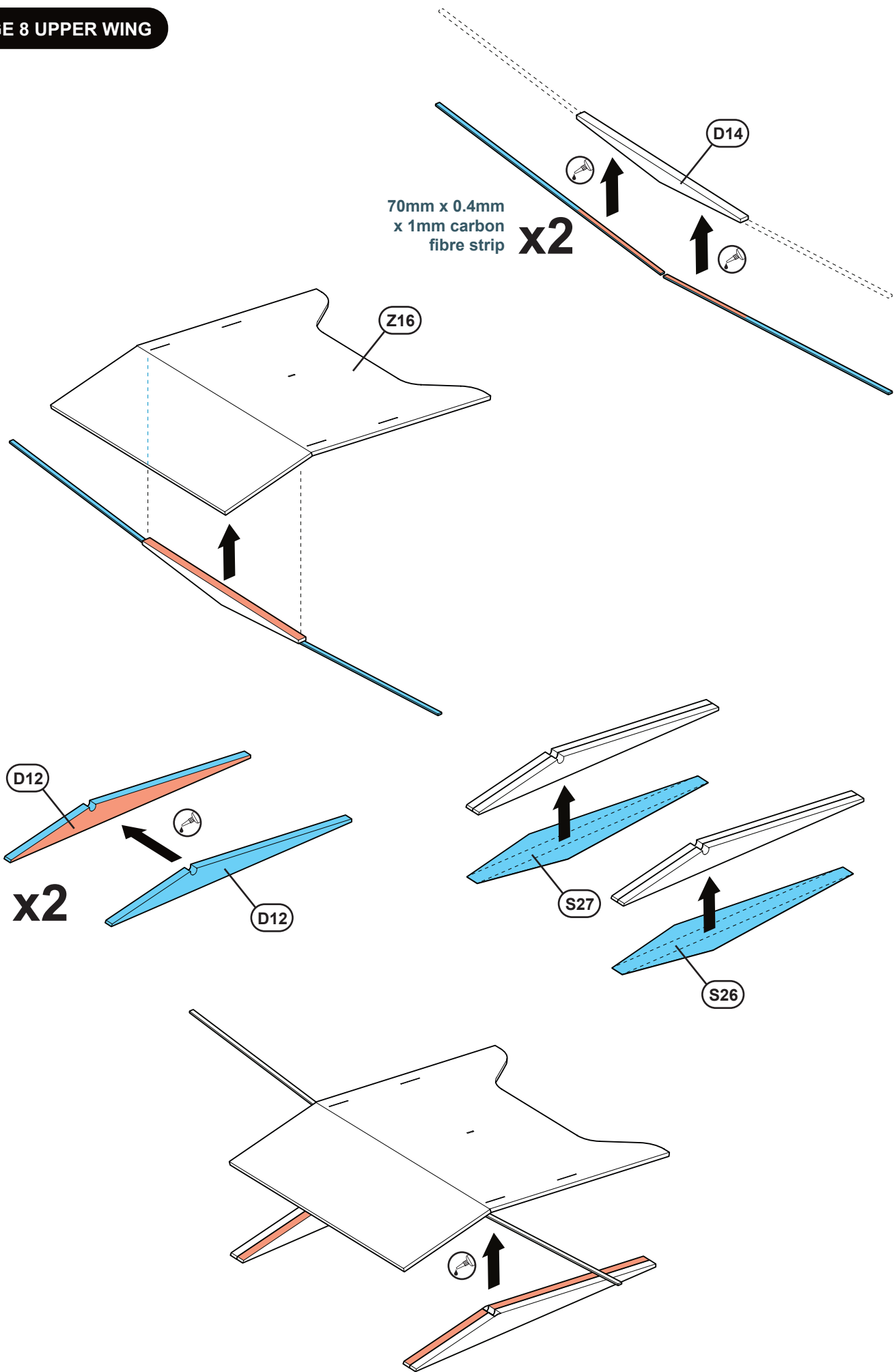

**STAGE 8 UPPER WING**

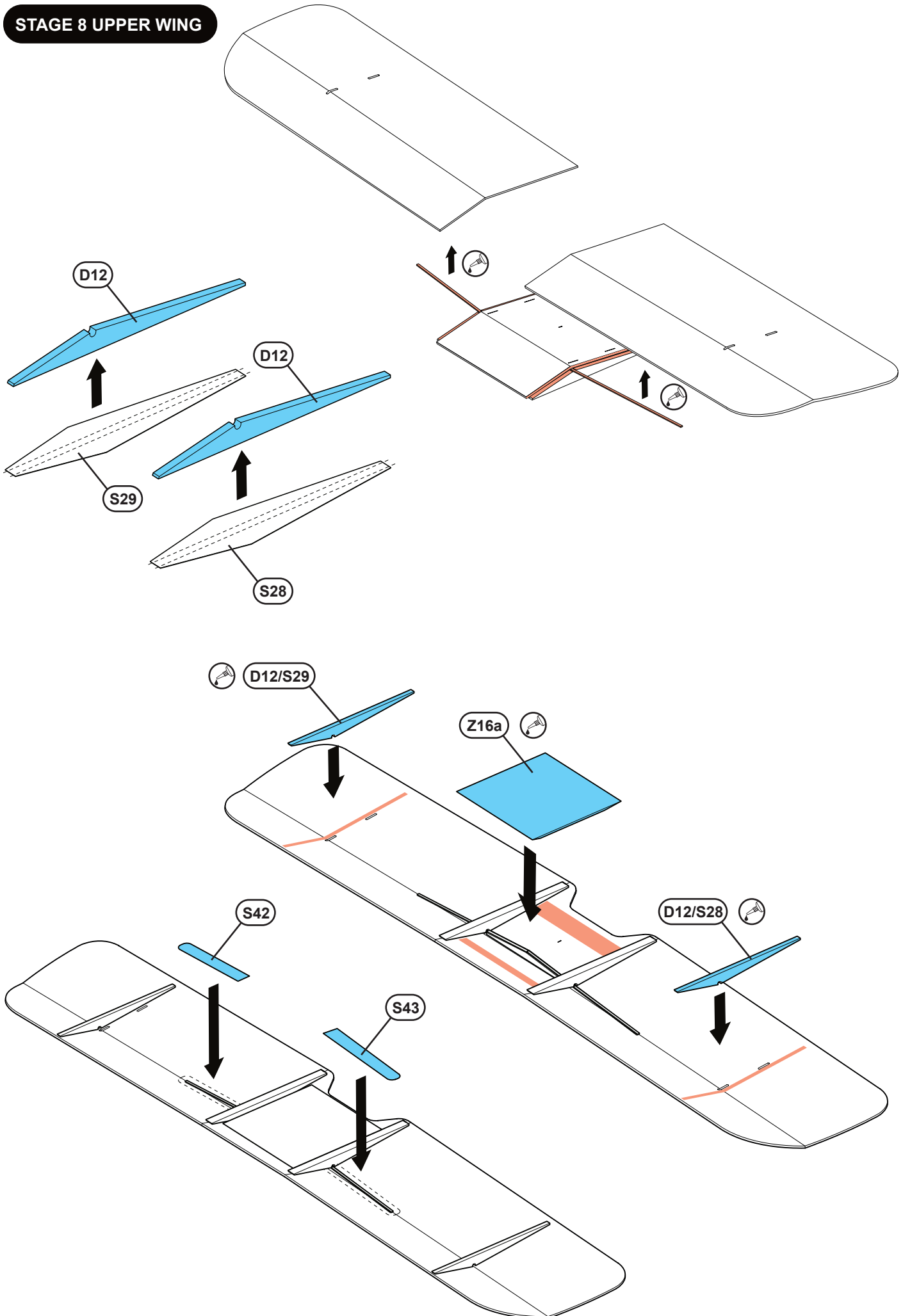

**STAGE 8 UPPER WING**

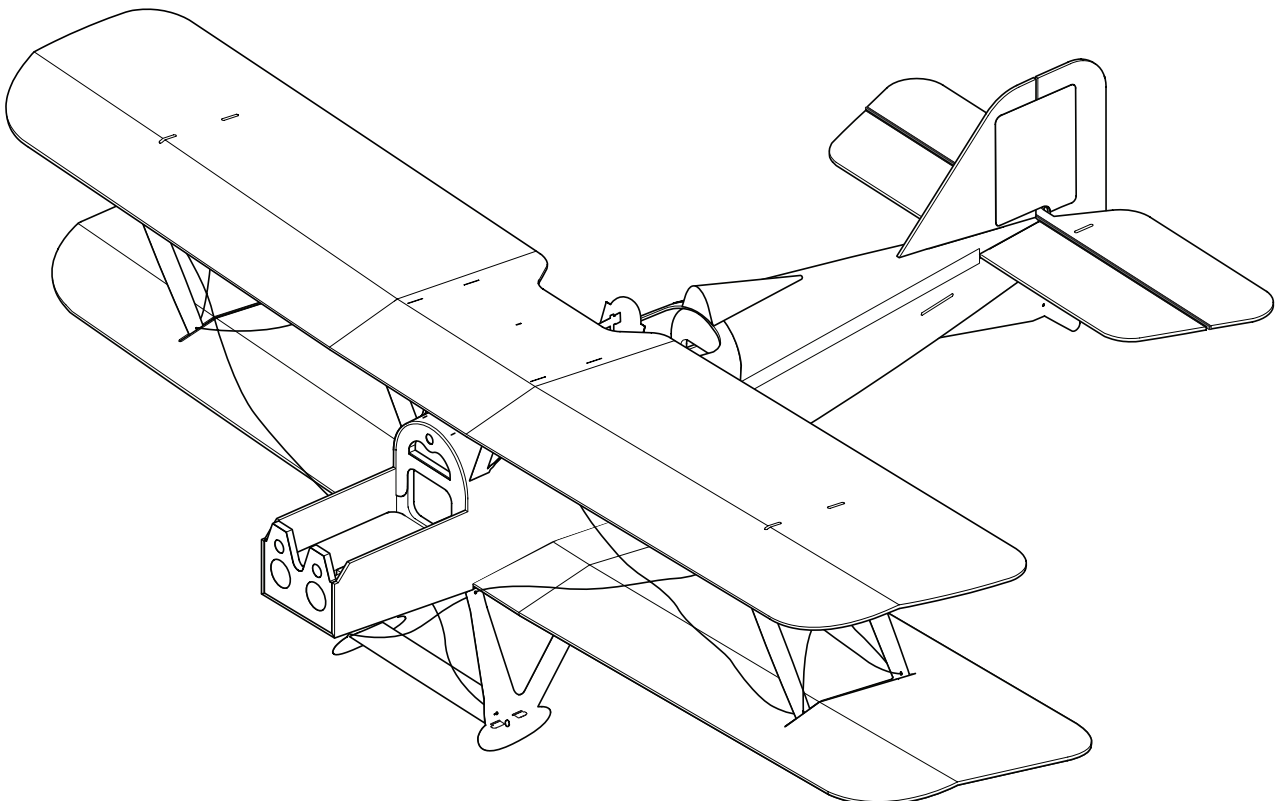
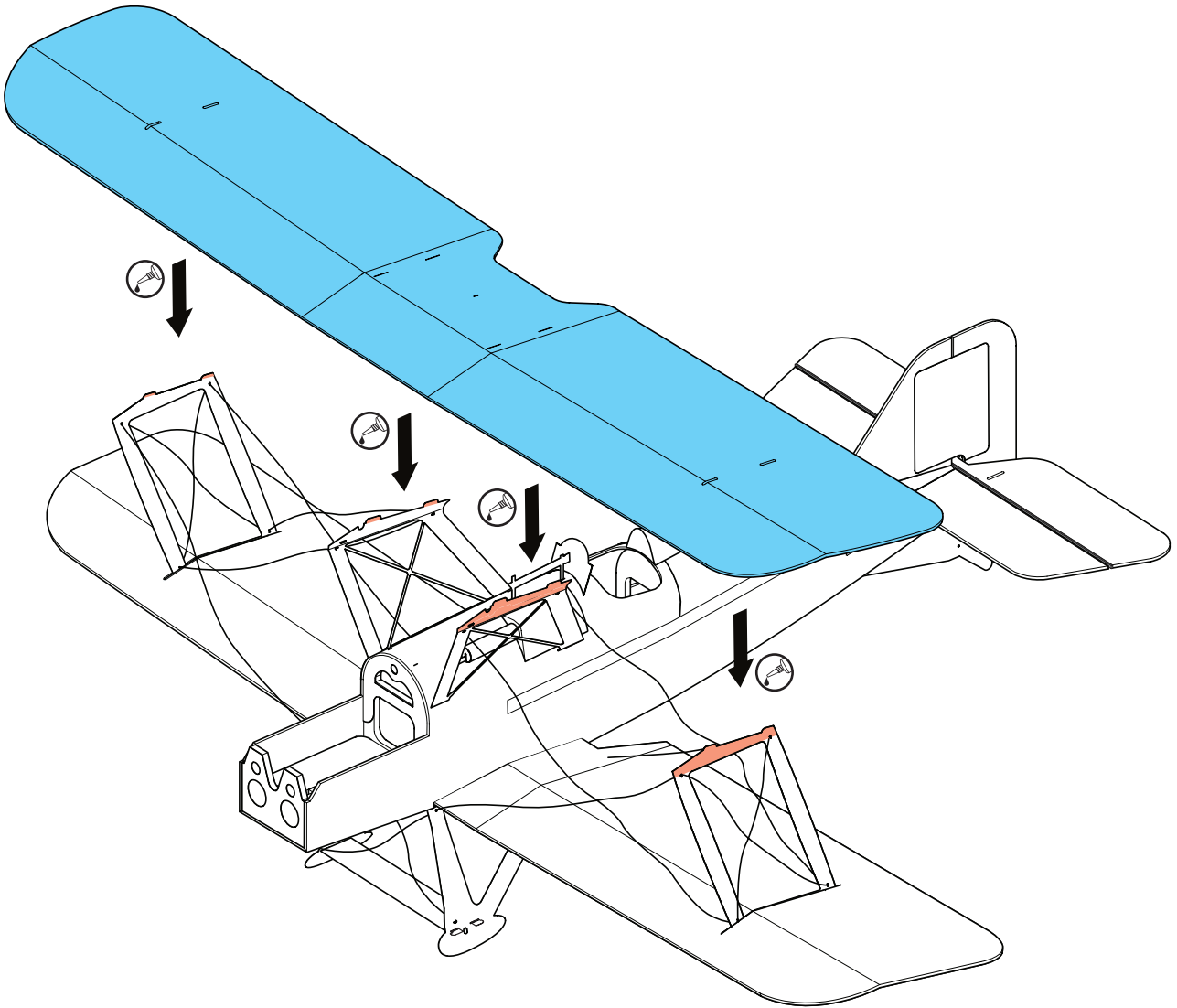

## STAGE 9 RIGGING TENSION

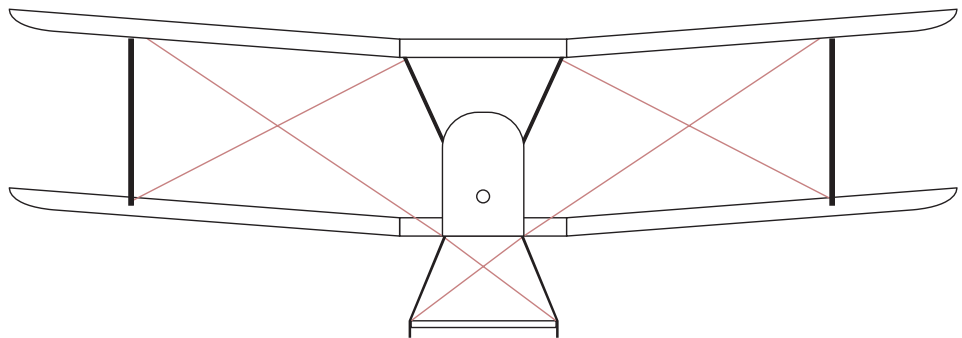
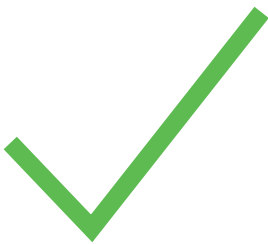
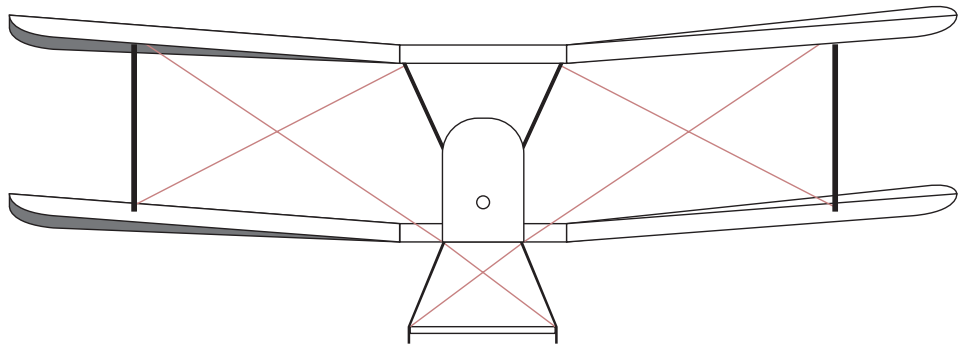
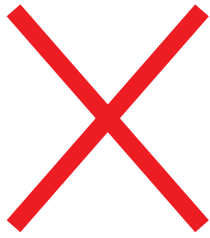
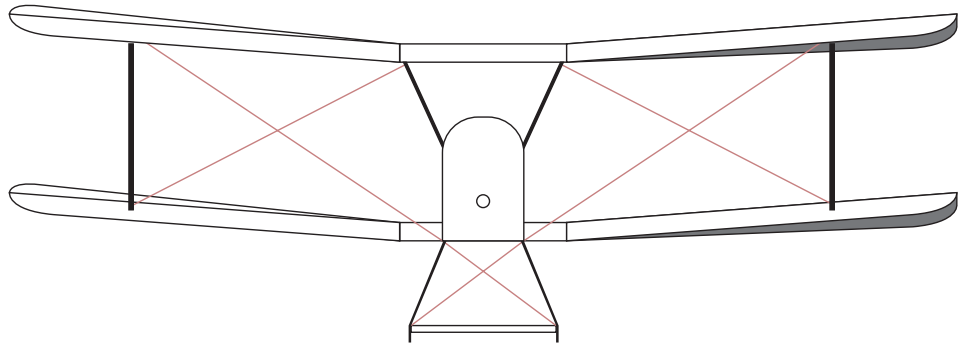

### Ensure correct alignment when tensioning the rigging

The rigging on the SE5a is functional. It strengthens and stabilises the wings to provide predictable flight characteristics so is important to get right!

Tension the wire between struts. Because of the shape of the laser cut holes in the struts, you can lock the thread at each point that it passes through a rigging hole.

Work on tensioning the wire on both sides of the aircraft simultaneously to help maintain symmetry. Secure the end points of the rigging to the underside of the wing once happy with the tension using foam safe CA or Aliphatic resin.

Check alignment visually then add a small amount of adhesive to each point where the rigging passes through strut work.

Trim excess rigging with a fresh blade.



Glue bottom of both Interplane struts to lower wing ribs.

**STAGE10 CHIN**

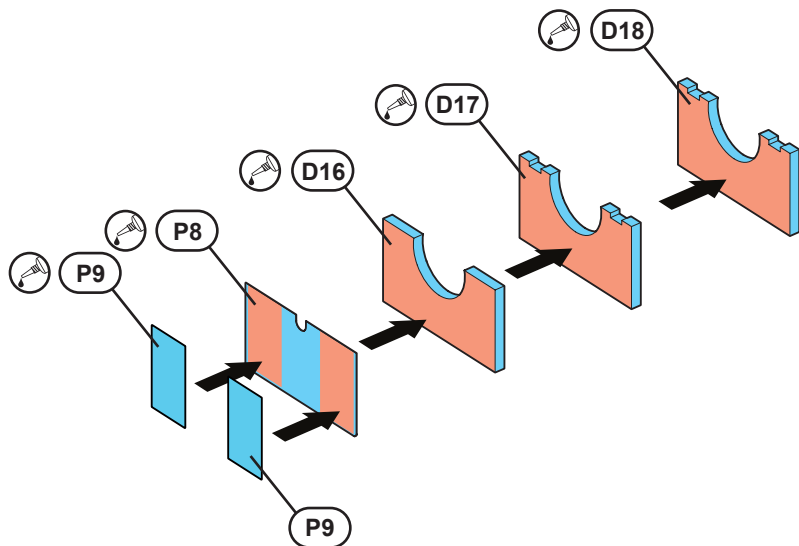

3mm Ø x 1mm Magnet's

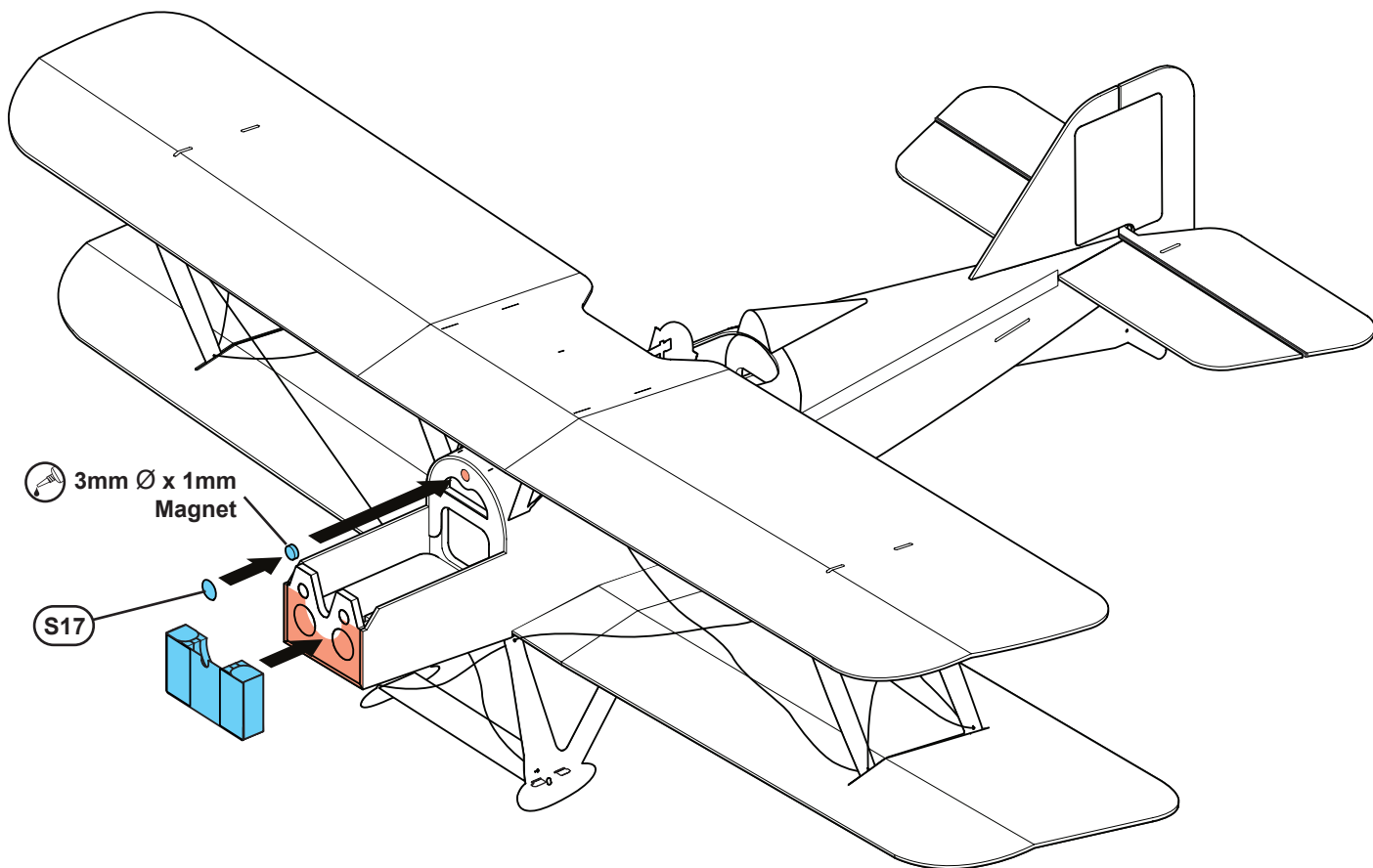
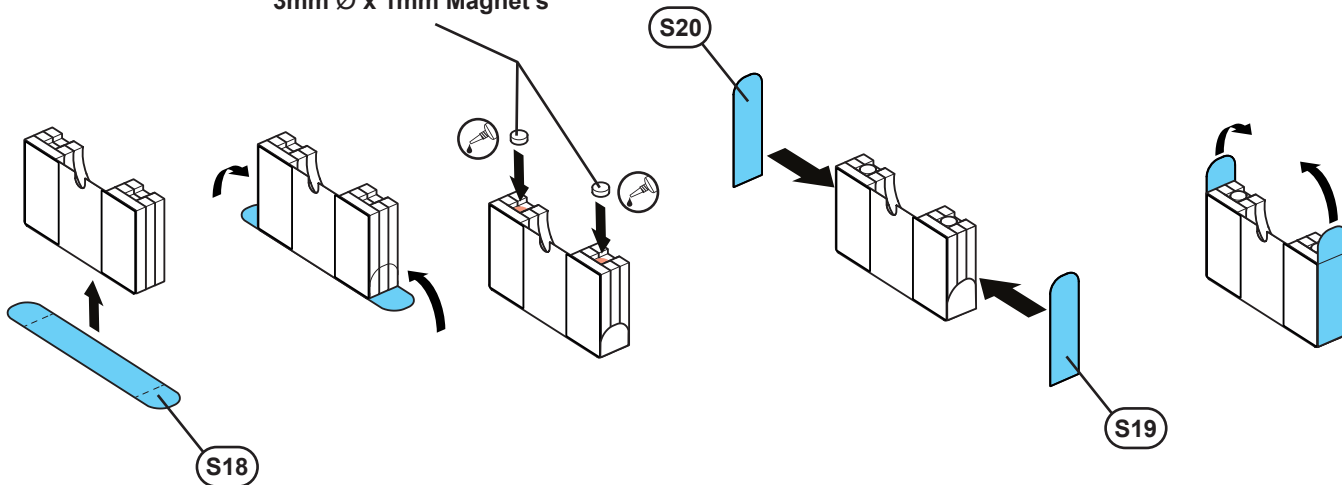

**STAGE 11 ACCESS HATCH**

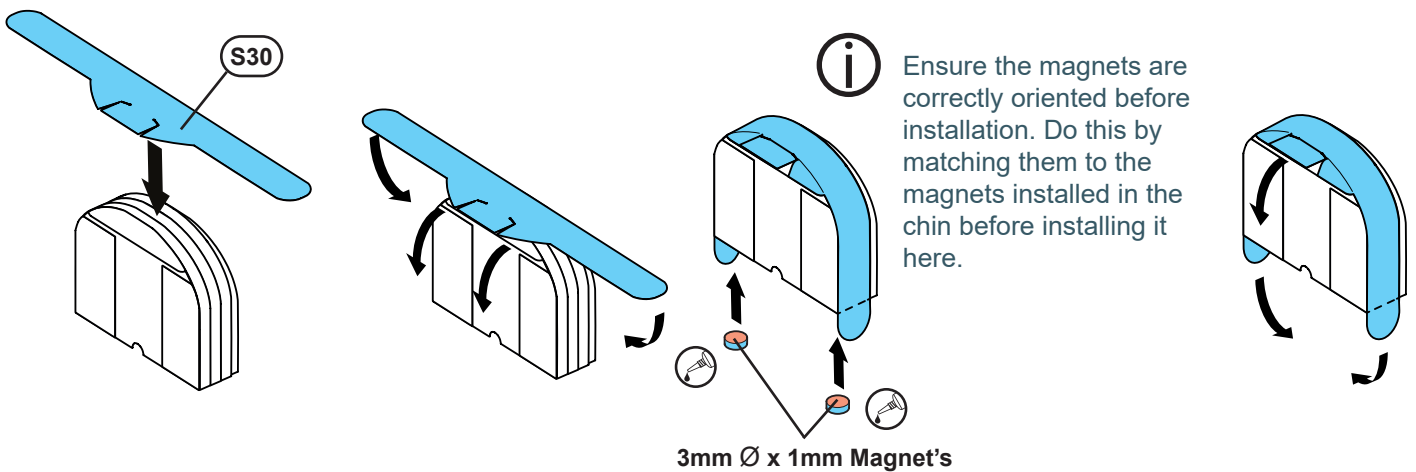
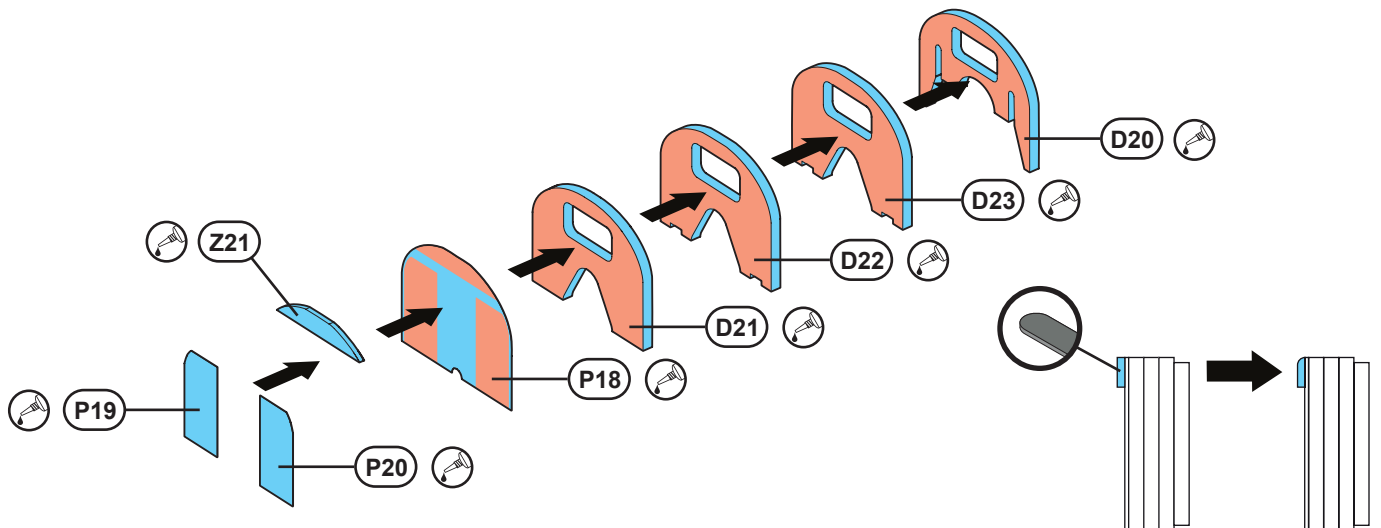

**i** Bevel & Score before installation - See Scoring & Bevelling guide #2

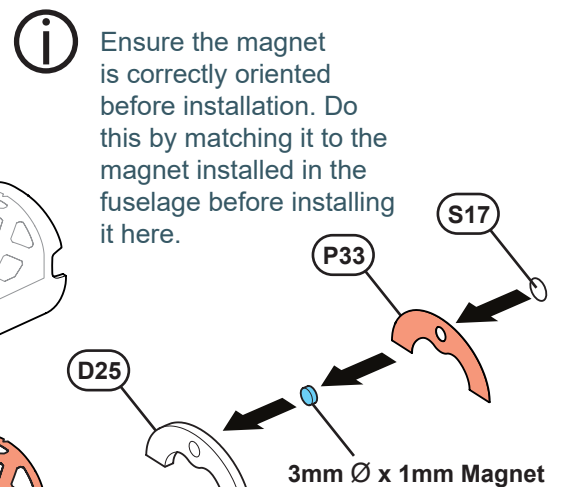
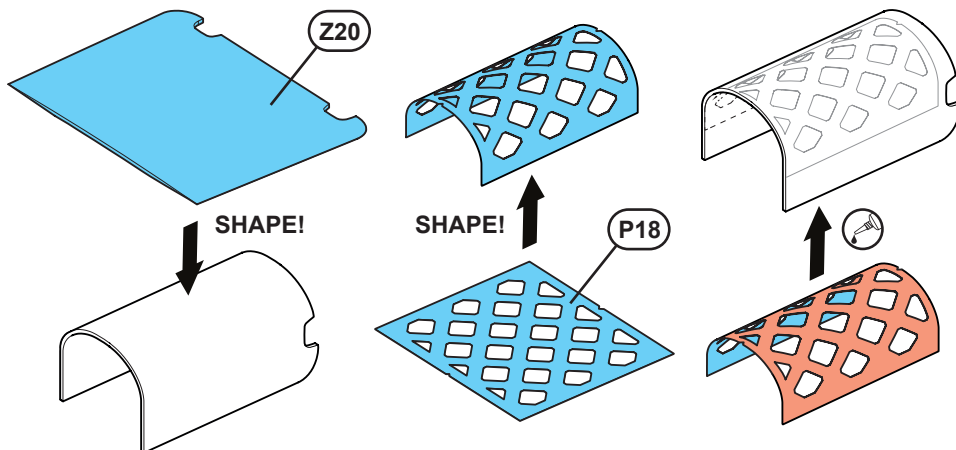

**STAGE 11 ACCESS HATCH**

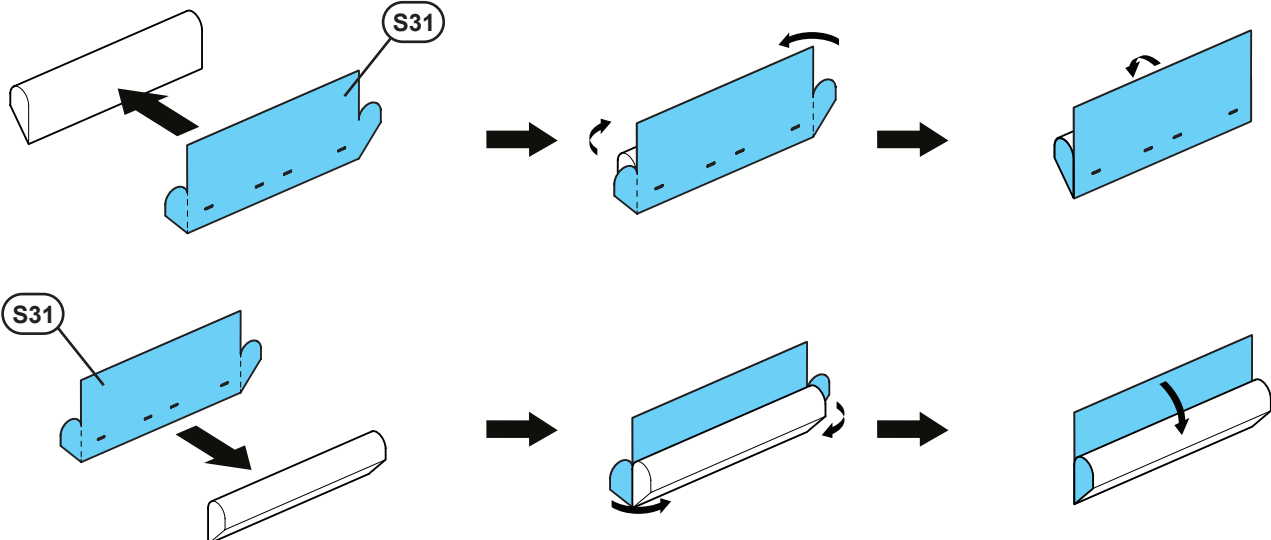
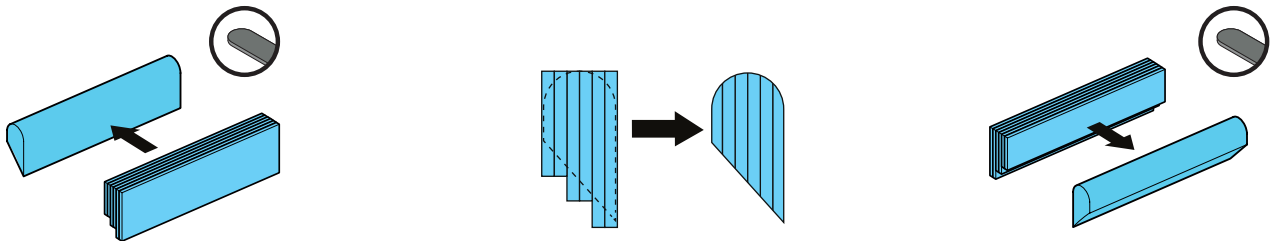
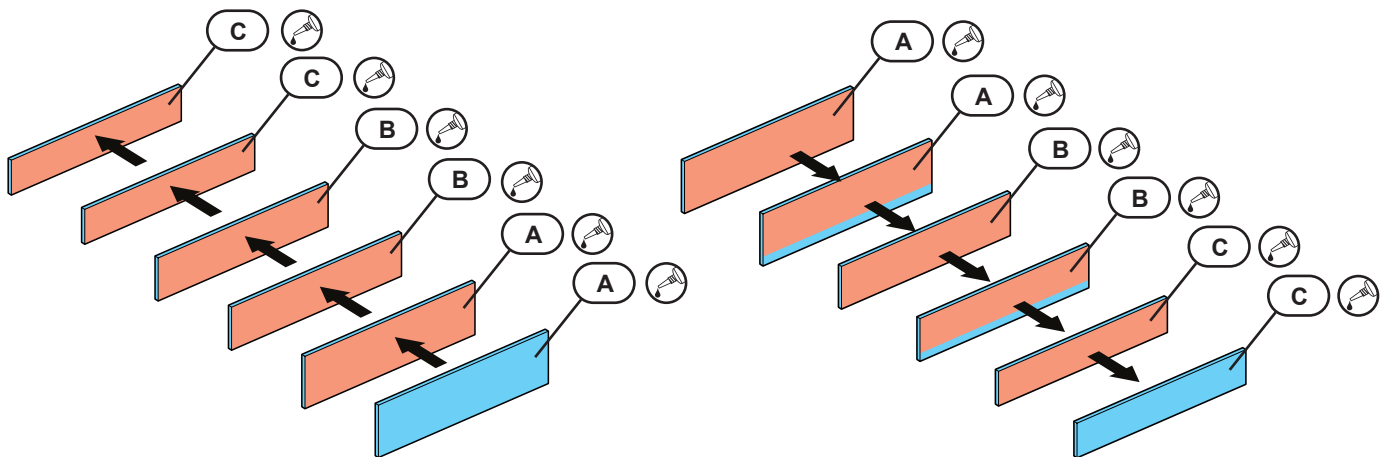
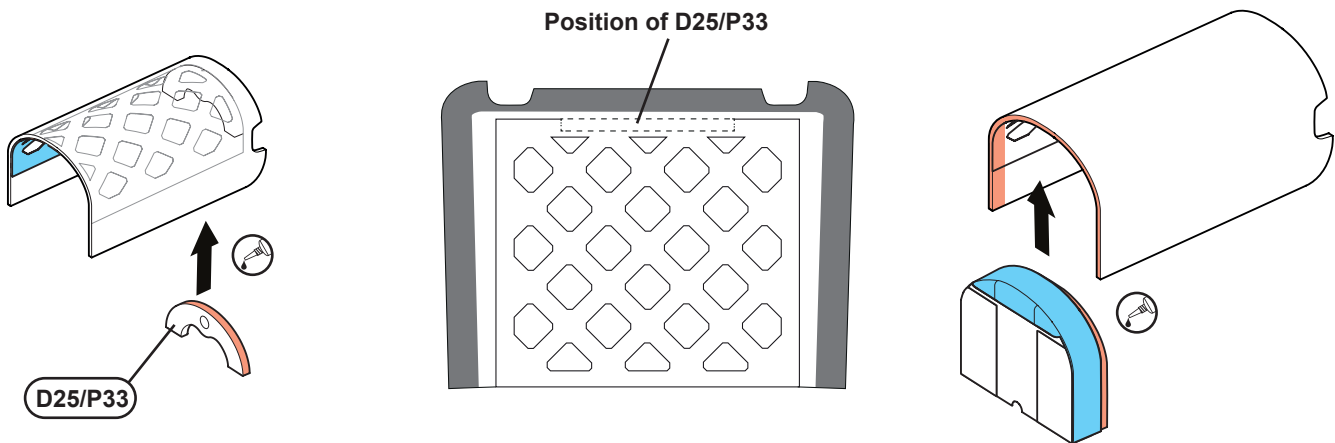

**STAGE 11 ACCESS HATCH**

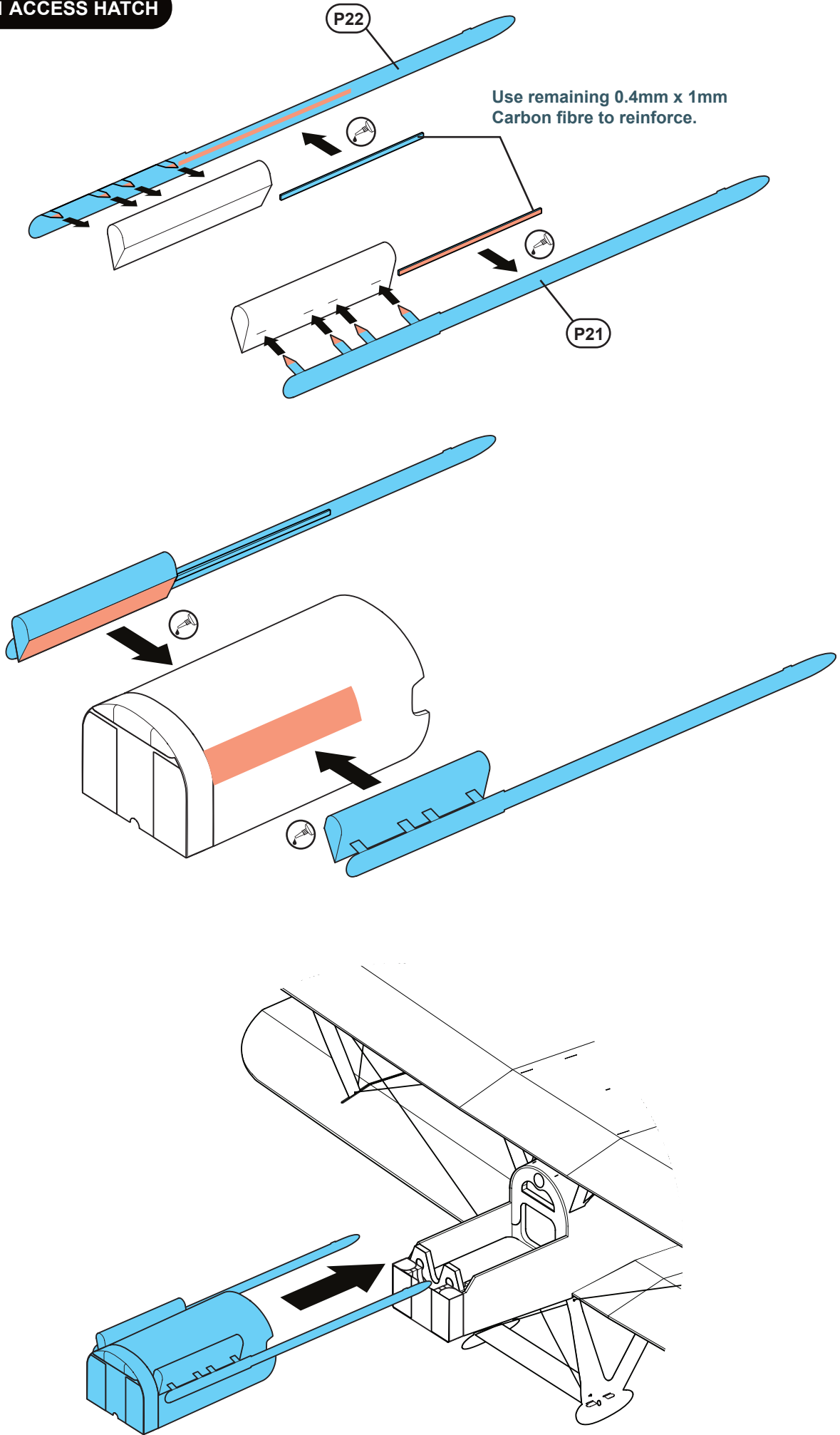



STAGE 12 WEAPONS

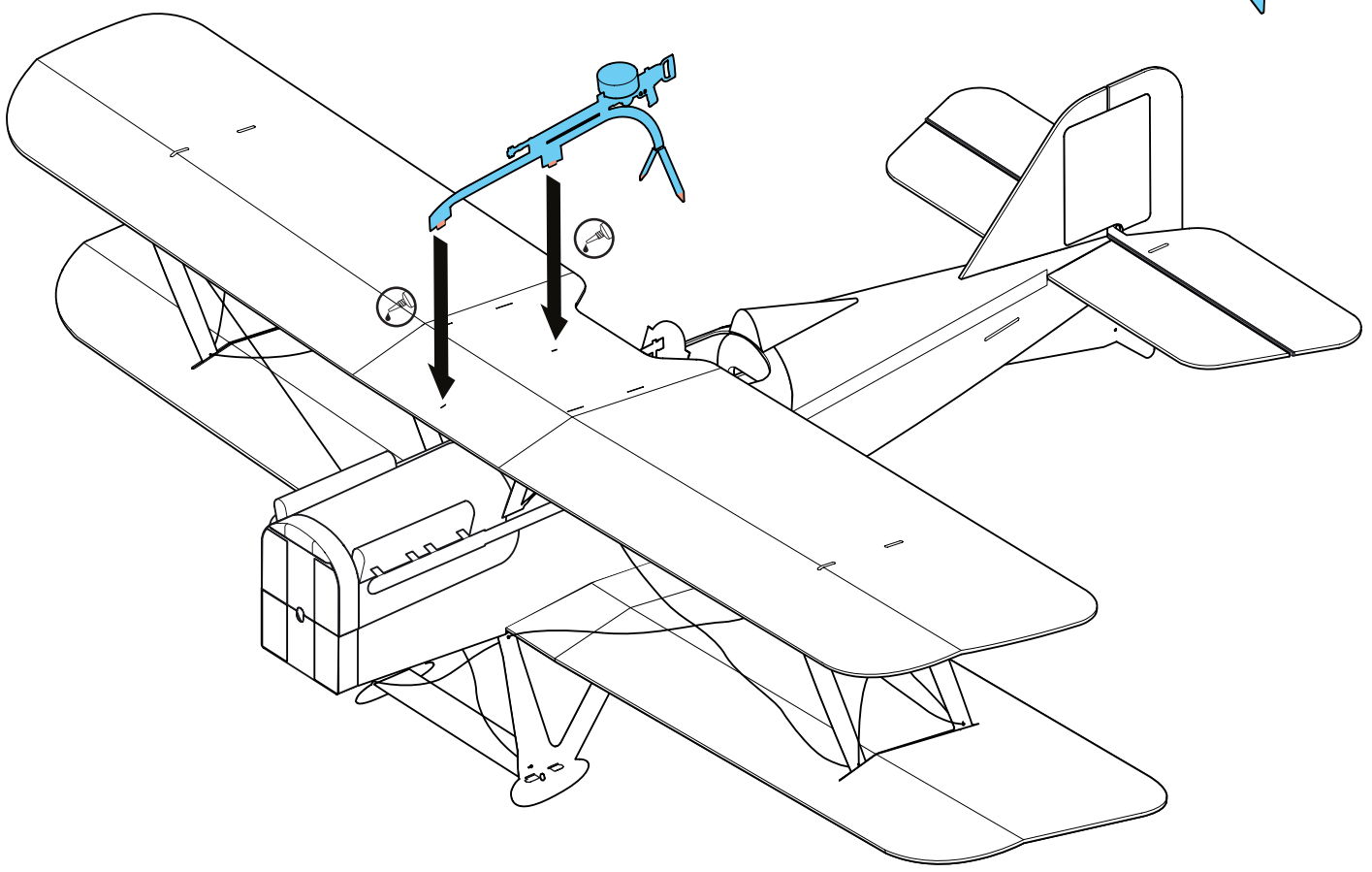
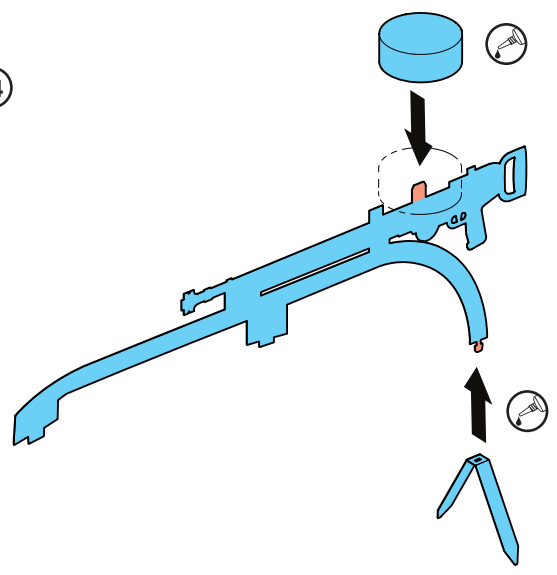
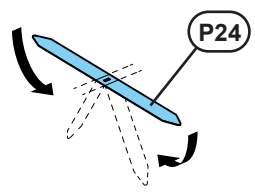
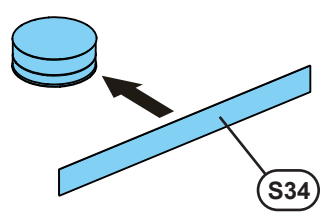
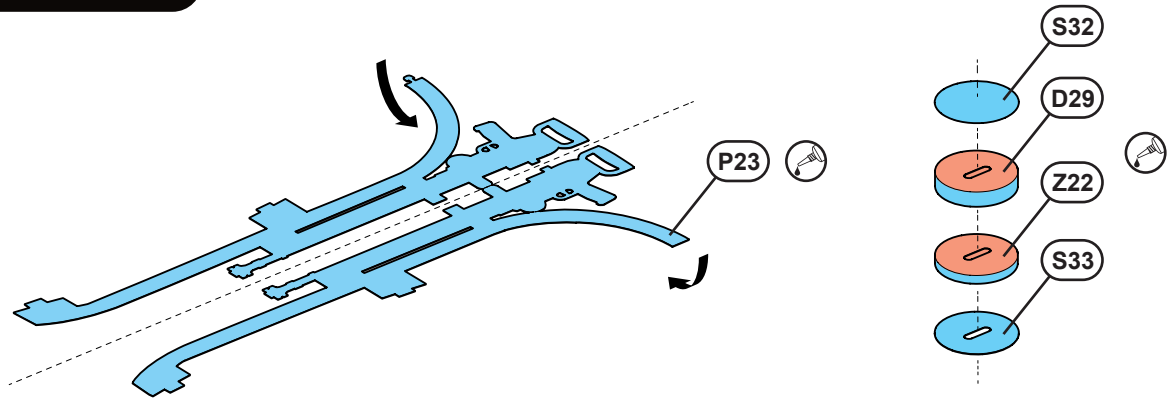

## STAGE 13 WHEEL ASSEMBLY



Bevel & Score Z11 before installation -  
See Scoring & Beveling guide #2



Assemble each wheel onto the axle  
temporarily to ensure good alignment.

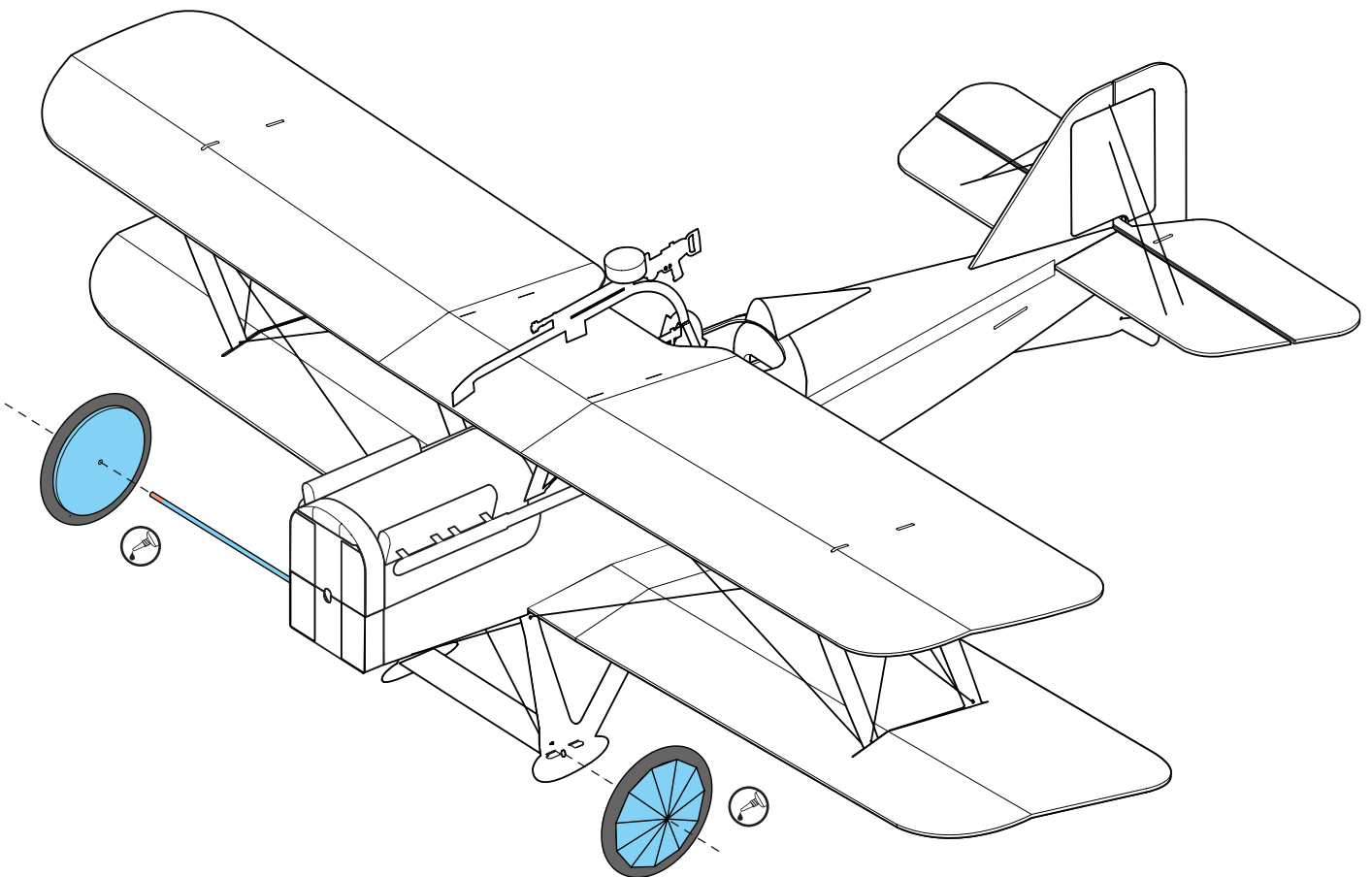
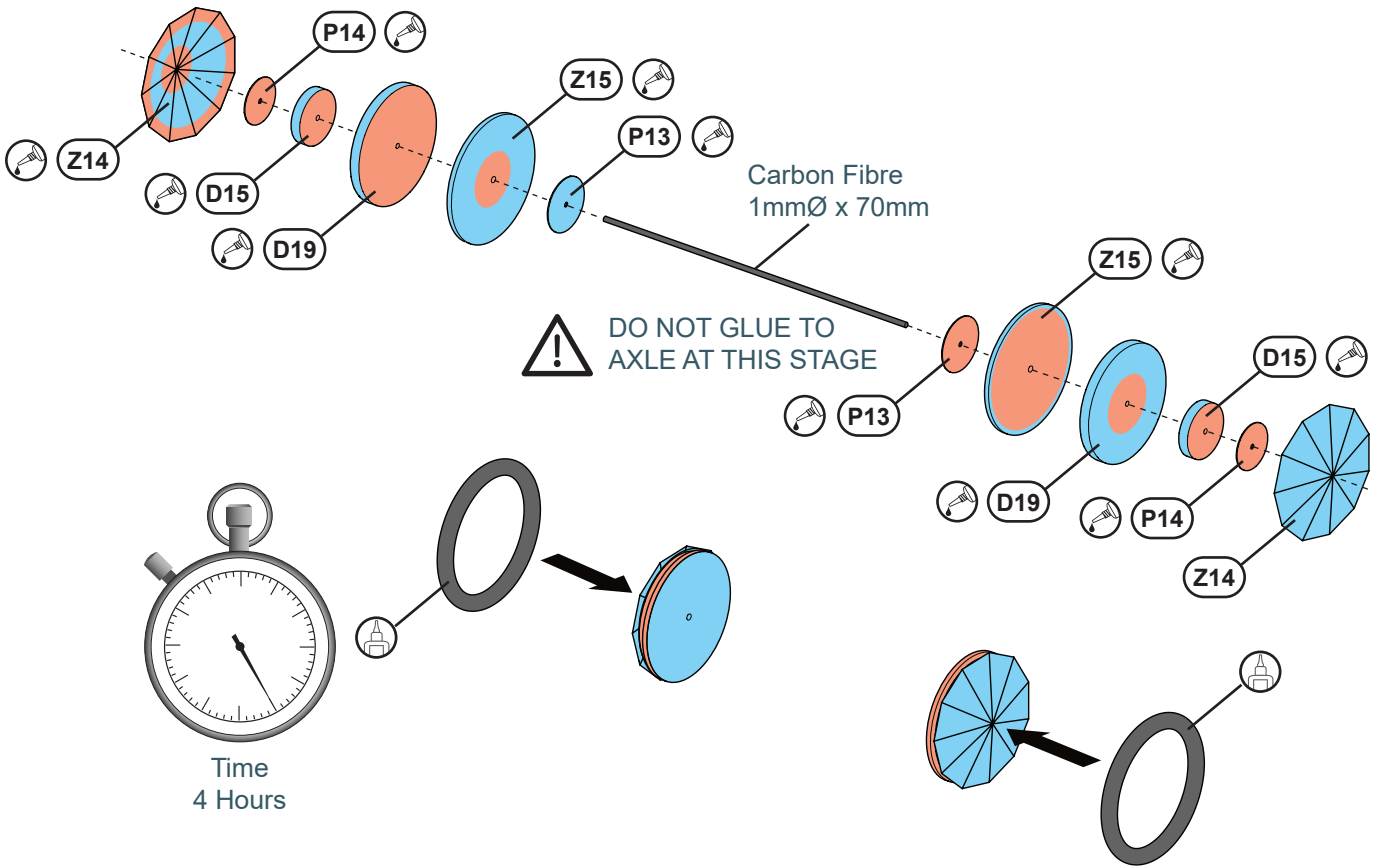

**STAGE 14 CONTROLS**

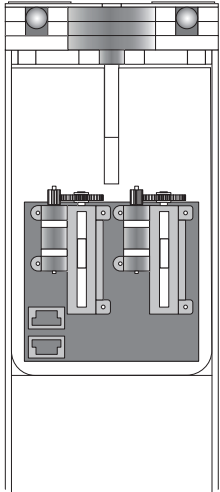

**i** Suggested position of receiver

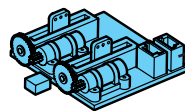

Receiver Brick

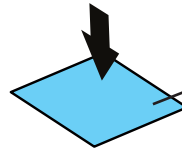

Double Sided Adhesive Pad

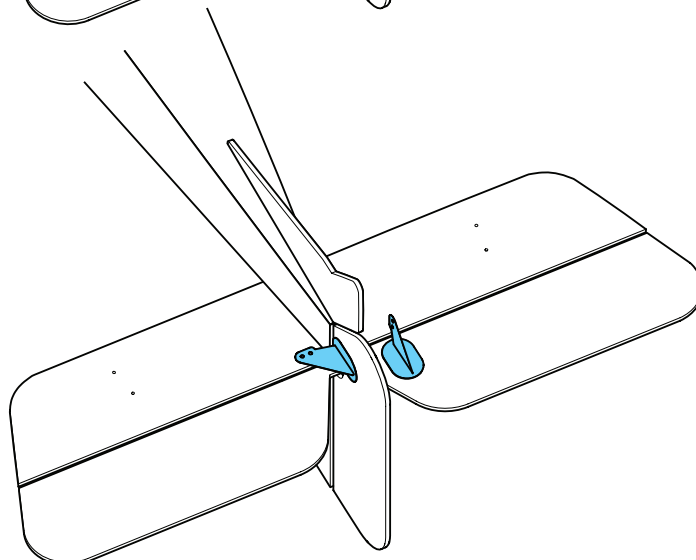
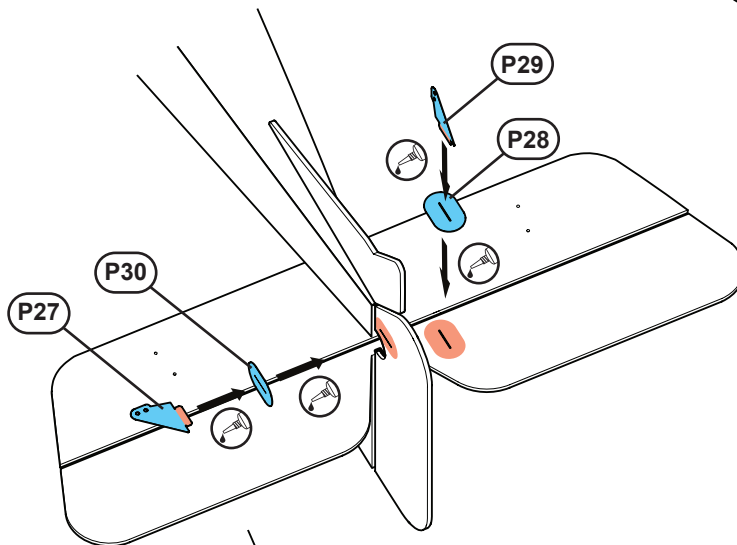
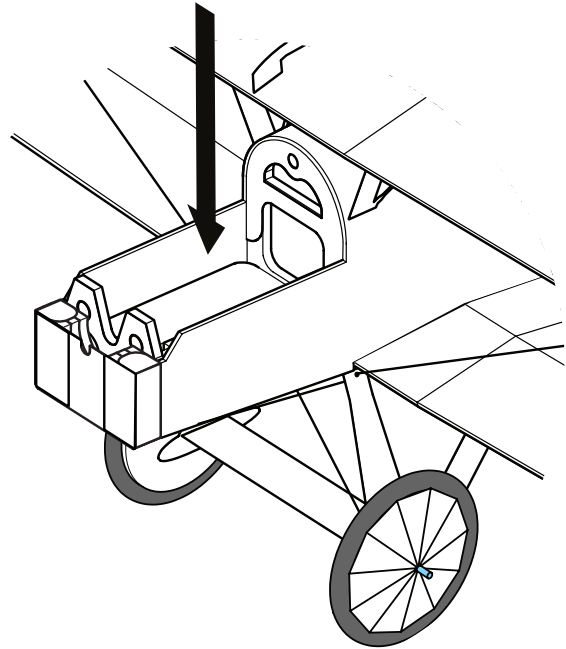

## STAGE 15 CONTROL RODS

- i** Insert individual control wire from the rear and attach to appropriate control horn. Set control surface to neutral then, using slim or needle nose pliers, bend the end of the control wire at the point it will need to attach to the servo arm. Un-hook the control wire from the control horn, pull out of the fuselage and complete the hook bend for the servo arm. Trim hook to 4mm in length.

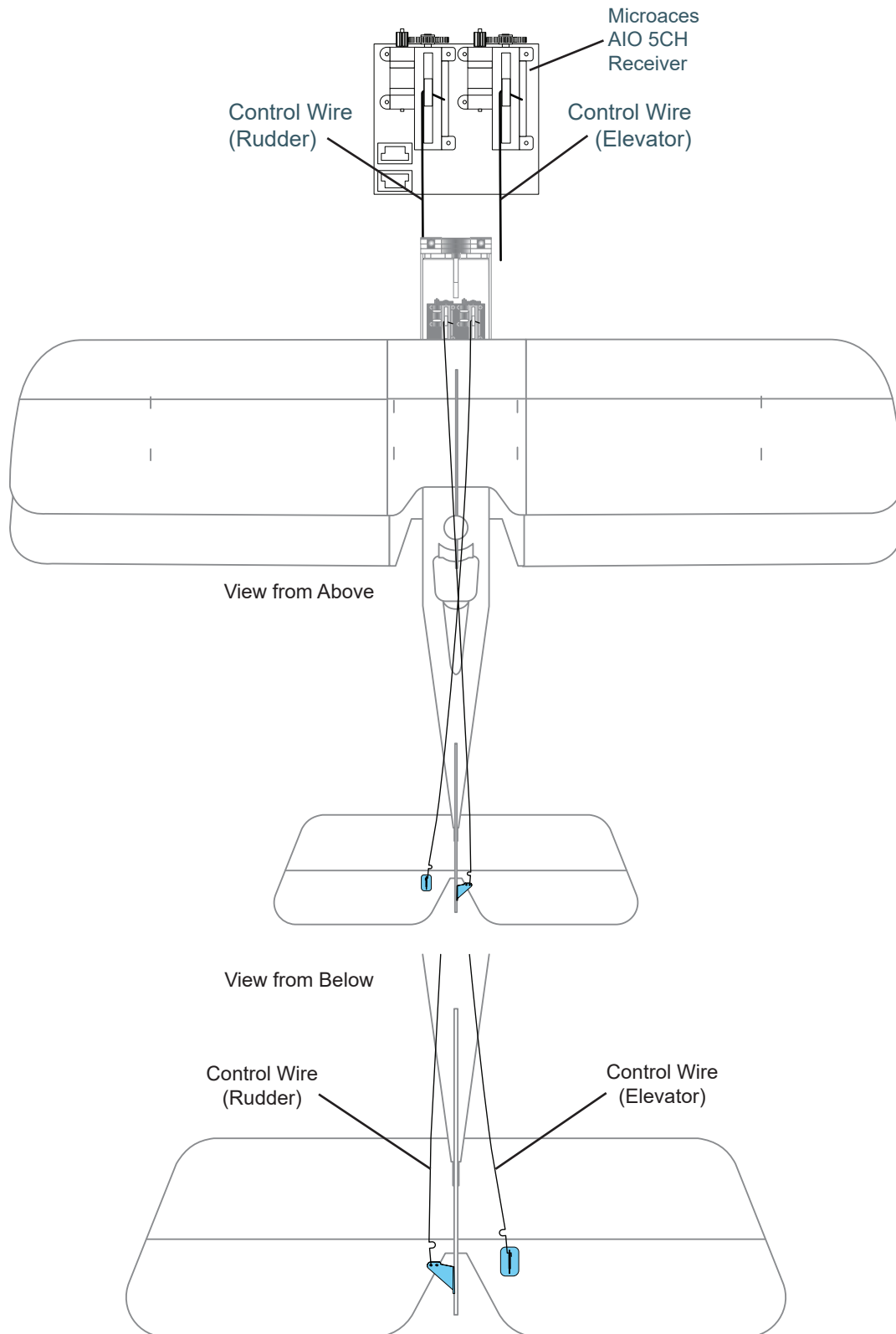

- i** The Control Horns for the rudder and elevator are very flexible. Install the control wires for each and use tweezers to bend the horns to insert the 'Z' bend into the hole.

Use the outer hole of the control horns for more gentle control of your aircraft!

**STAGE 16 RIGGING - TAIL**

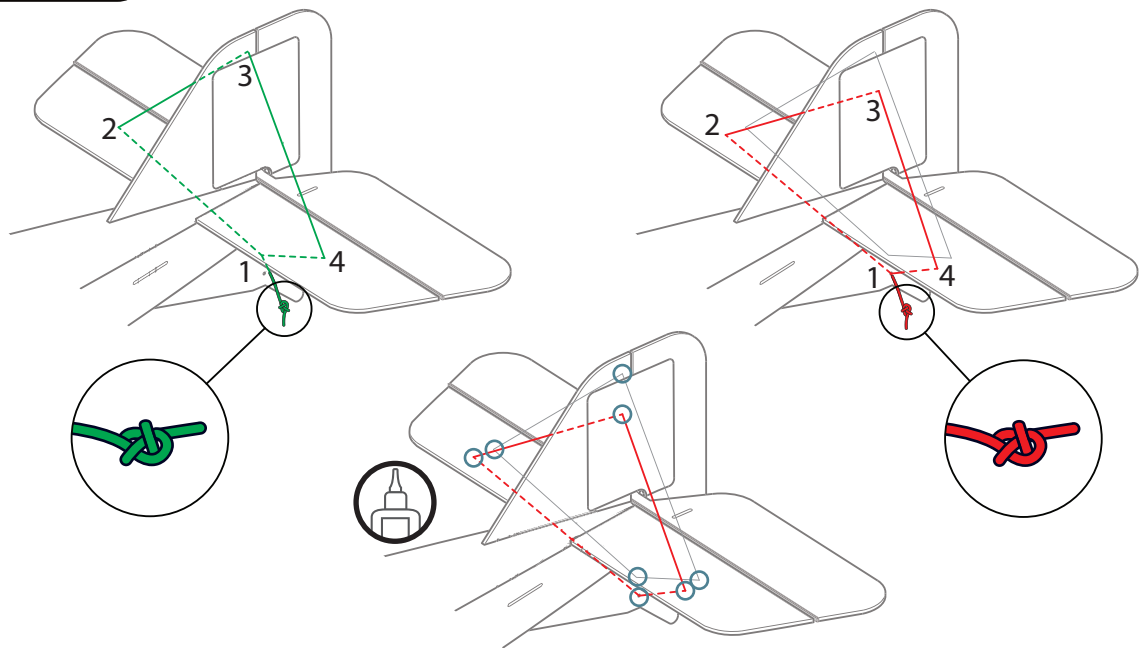

**STAGE 17 DETAIL**

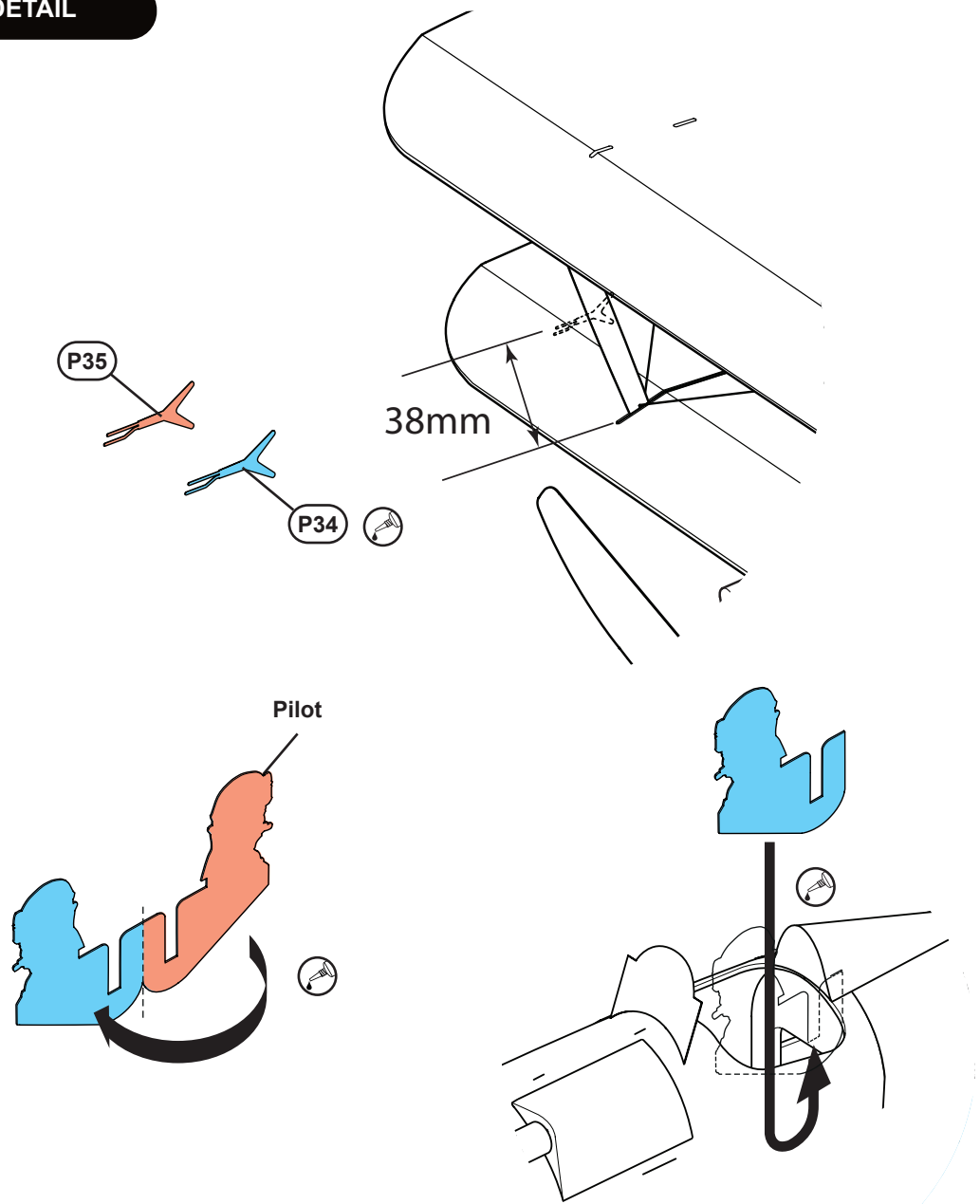

# STAGE 18 MOTOR & PROPELLER

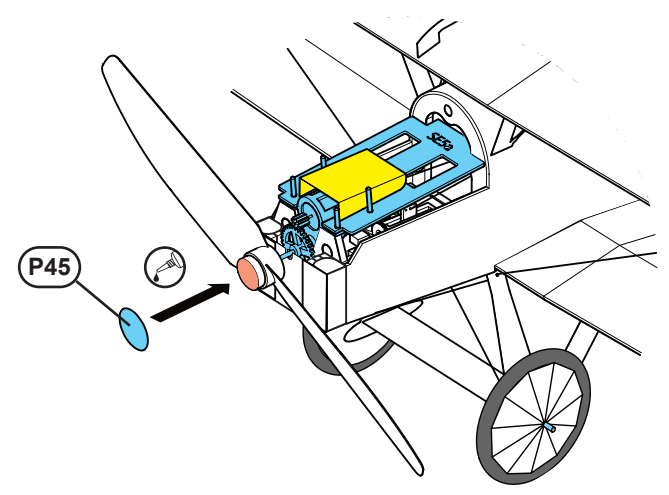
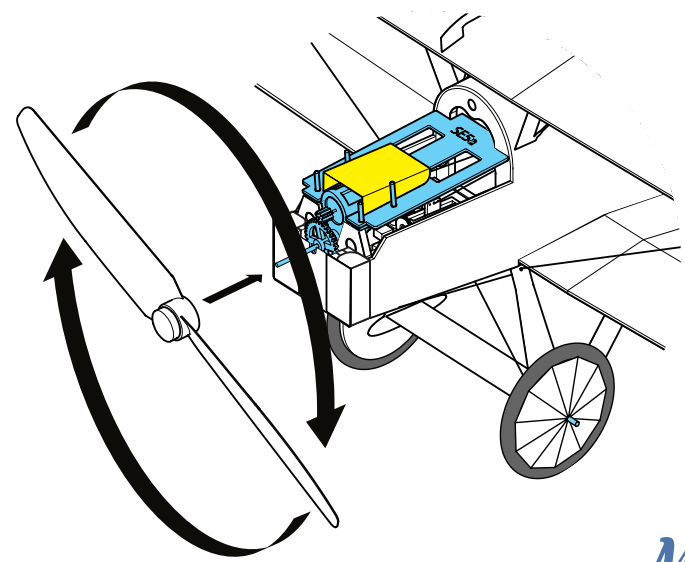
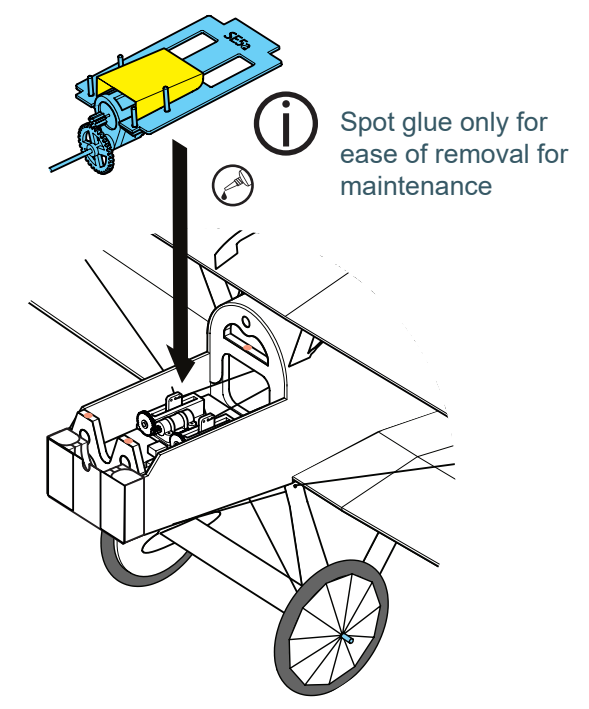
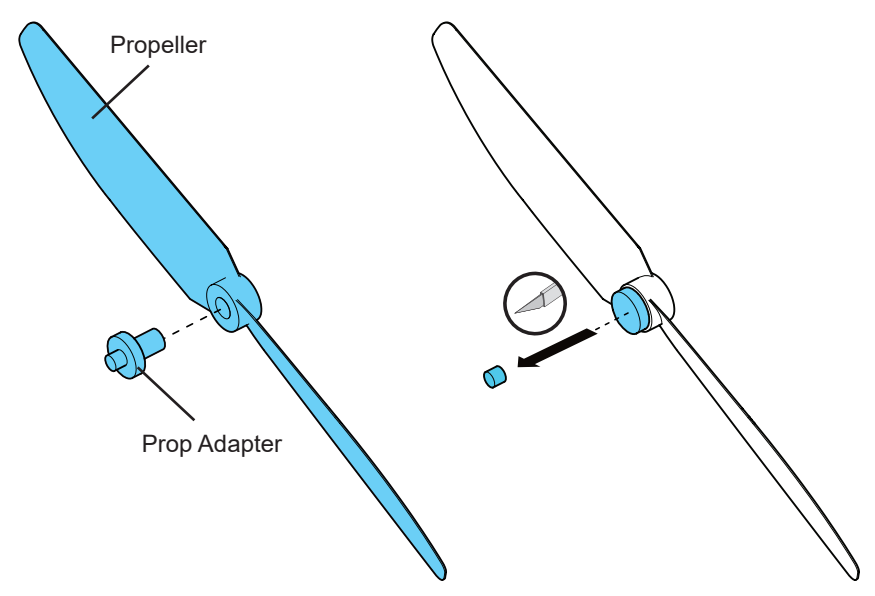
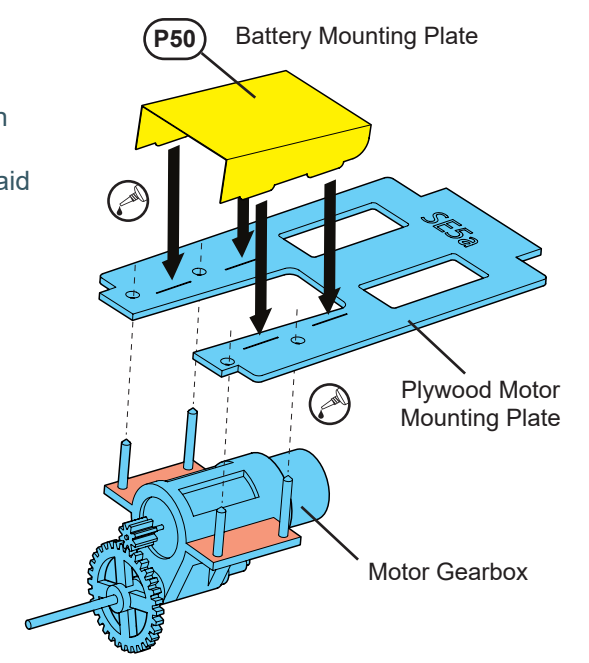
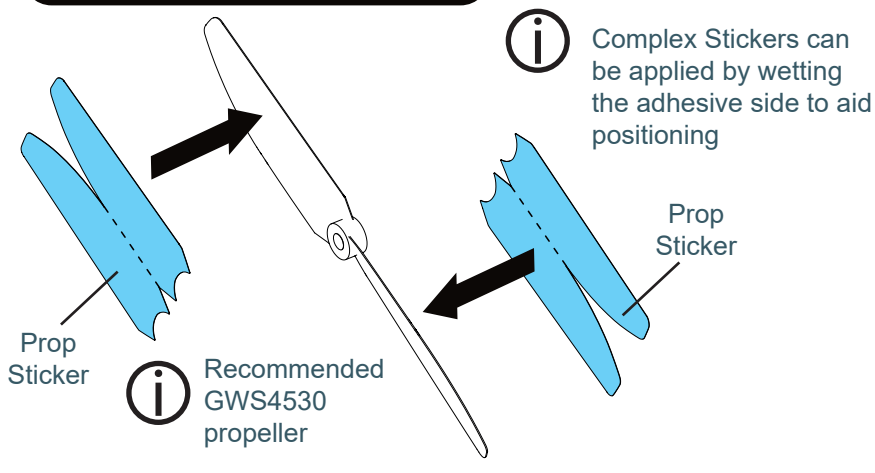

## STAGE 19 FINISHING TOUCHES

### Centre of Gravity (CoG)

With all the electronics installed including the battery, the CoG should be around the apex of the top wing as shown on the diagram below.

Balance on finger tips to see if the aircraft balances at this point. Before adding any weight it is advisable to perform a glide test. Add weight accordingly to obtain a smooth glide.

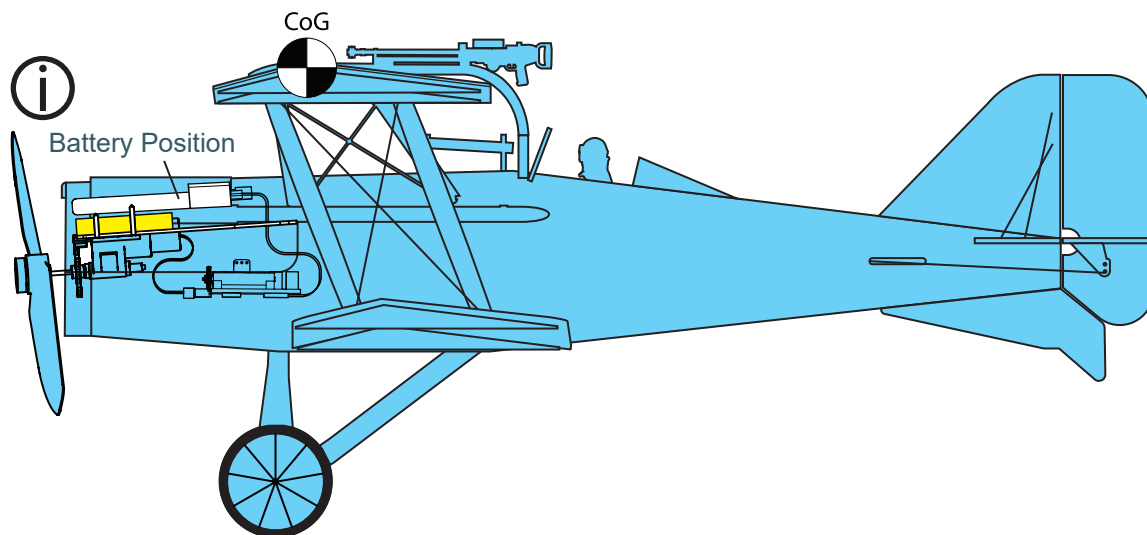

### Glide Test - How to!

*Tail Heavy  
Add weight to Nose!*

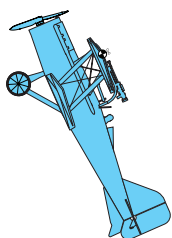

Find a suitable test space with a forgiving landing area, e.g. over long grass or onto soft furnishing. Ensure all control surfaces are in the neutral position. Gently toss the model straight and level. Observe the results and add balancing weight if required.

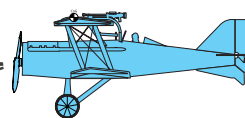

*Spot On!*

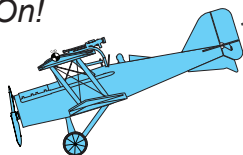

*Nose Heavy  
Add weight to Tail!*

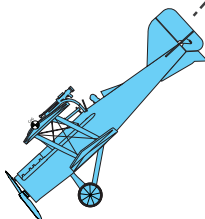

### Radio Control Recommendations

The control surfaces are very effective on the SE5a. Set your transmitter (Tx) control rates to low or if you have a computerised Tx, set the expo to 50% for both the rudder and the elevator.

Feel free to adjust these to suit your flying style after the maiden flight!